

GRAPHIC NOVEL / MEDIA THE-IN / ISBN 0-671-00104-3 / \$18.00 U.S. / \$24.00

MTV'S THE HEAD

A LEGEND IS BORN

MTV BOOKS / POCKET BOOKS



THE HEAD

A LEGEND IS BORN



**CREATED BY
ERIC FOGEL**
WRITTEN BY
ERIC FOGEL AND
GORDON BARNETT

**A COMPLETELY
ORIGINAL ADVENTURE
BASED ON THE SERIES'
LOST EPISODE!**



ISBN 0-671-00104-3



WRITTEN BY
ERIC FOGEL AND
GORDON BARNETT

THE HEAD

A LEGEND IS BORN

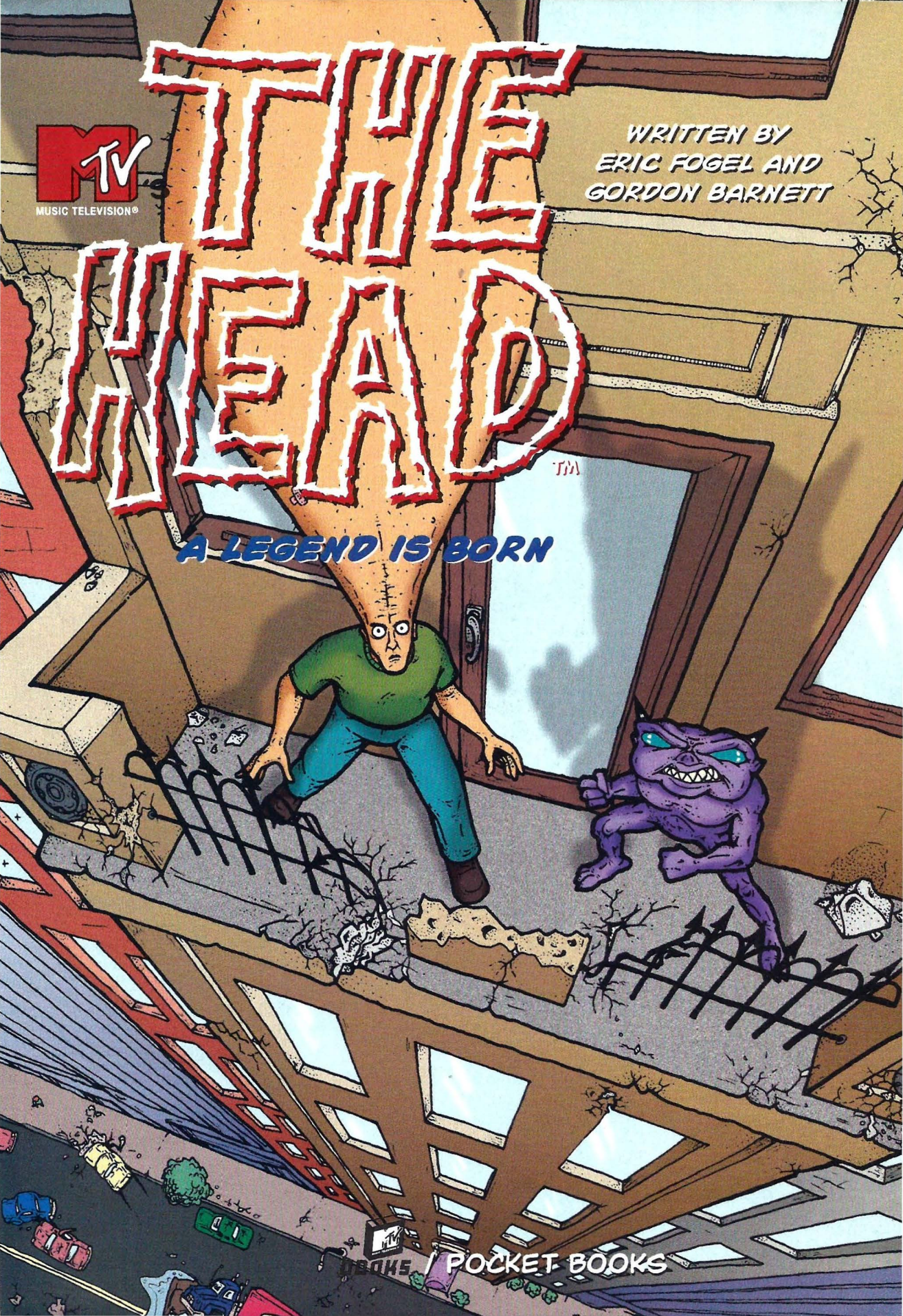

POCKET BOOKS / POCKET BOOKS



THE CAST

JIM

OUR HERO. BASICALLY A NORMAL GUY WITH A FEW EMOTIONAL PROBLEMS TO WORK OUT. HE LED AN ORDINARY LIFE UNTIL HE MET ROY AND WAS SWEEPED INTO A WORLD OF ACTION AND ADVENTURE.

ROY

JIM'S SYMBIOTIC ALIEN FRIEND. HE LIVES RENT-FREE INSIDE JIM'S HUGE HEAD AND HELPS HIM WORK OUT HIS PROBLEMS.

MARK

ROY'S YOUNGER BROTHER. HE'S ALWAYS BEEN A SCREW-UP AND A DISAPPOINTMENT.

MADELINE

JIM'S GIRLFRIEND. LOYAL AND TRUE, SHE STANDS BY JIM THROUGHOUT ALL HIS UPS AND DOWNS.

GORK

EVIL PARASITIC ALIEN WHO ONCE ATTEMPTED AN INVASION OF EARTH. WHEN THE INVASION WAS REPELLED, GORK WAS BANISHED BY THE PARASITES AND LEFT TO FEND FOR HIMSELF ON EARTH.

DR. AXEL

JIM'S PERSONAL PHYSICIAN. HIS ABILITY TO FASHION IMPROVISED MEDICINAL CURES MAKES HIM AN INDISPENSABLE ALLY.

DR. ELLIOT

FORMER LEADER OF GOVERNMENT SPONSORED EXTRA-TERRESTRIAL INVESTIGATION PROGRAM. HIS SEARCH FOR AN ALIEN PRESENCE ON EARTH DROVE HIM TO INSANITY. CURRENT WHEREABOUTS...UNKNOWN.

THE HUMAN ANOMALIES

JIM'S LOYAL AND TRUSTWORTHY FRIENDS FROM HIS SUPPORT GROUP.

CHIN

AFFLICTED WITH LONG LIMB SYNDROME.

IVAN

BORN WITH A MOUTH EMBEDDED IN HIS CHEST.

RAY

A GARDENING ACCIDENT LEFT HIM WITH A LAWNMOWER BLADE LODGED IN HIS SKULL.

RAQUEL

LOOKS LIKE A RAT.

CHAPTER ONE

URBAN BLIGHT



HECK YES, I'M A HERO. A REAL-LIFE TRUE BLUE SELF-SACRIFICING AMERICAN HERO. NO. I'M MORE THAN JUST AMERICAN. I'M A CITIZEN OF THE WORLD. OF THE GALAXY.



I HELP PEOPLE WITH THEIR PROBLEMS.



I THROW GREAT PARTIES AND EVERYONE HAS A GOOD TIME. I SAVE WHOLE PLANETS FROM LITTER DESTRUCTION



AND WHAT DOES IT GET ME? WORK? MONEY? A DECENT APARTMENT? FRIENDS? YEAH, RIGHT.

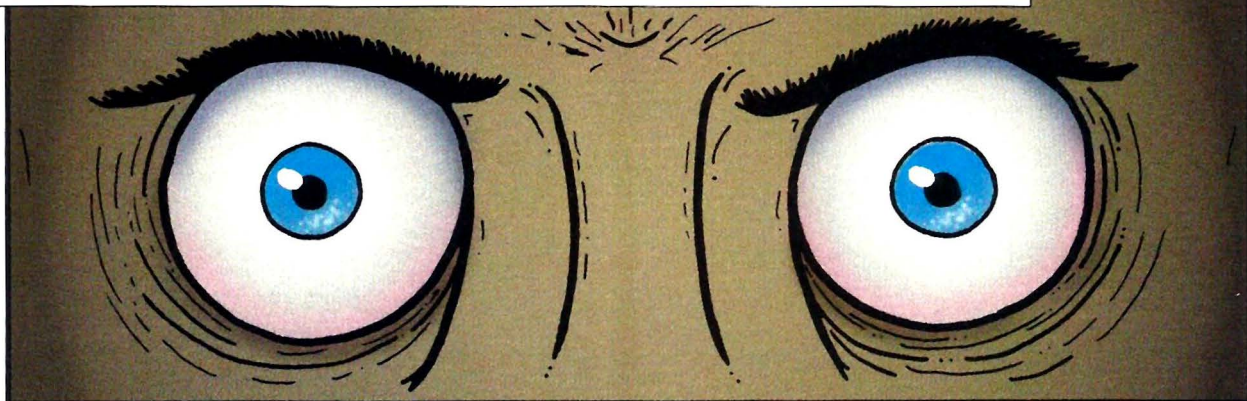

I MISS THOSE GUYS. THE OL' GANG, ADVENTURE AFTER ADVENTURE. NOTHING COULD STOP US.



AND ROY. MY BEST BUDDY ROY. HE LEFT ME, TOO. DAMN IT. IT'S A CRUEL, CRUEL WORLD.

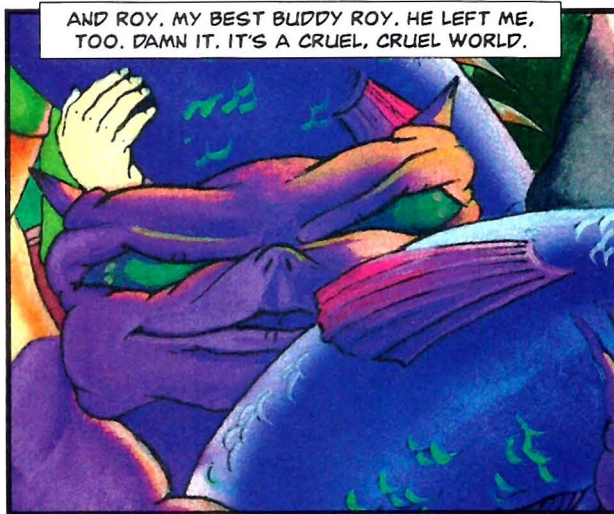

CRUEL...AND UNGRATEFUL!



EVEN MADELINE'S AGAINST ME NOW. SHE'S GOT ALL THIS ADVICE FOR ME. "GET A JOB." "FINISH SCHOOL."
"TAKE A SHOWER." I'M NOT LOOKING FOR ANY ADVICE. NOT FROM MADELINE. NOT FROM ANYONE

SCREW 'EM ALL.

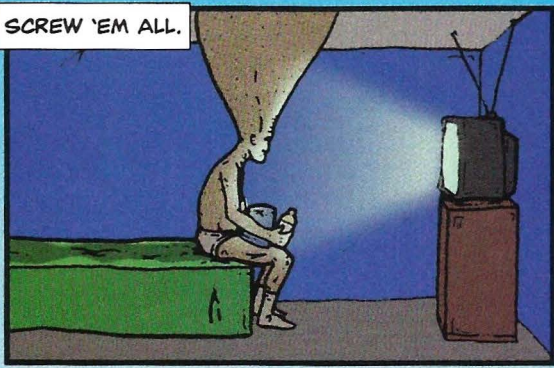

MY DARLING ROY, YOU ARE SO UNLIKE 'ZE OTHER AMERICAN MEN THAT I HAVE KNOWN.

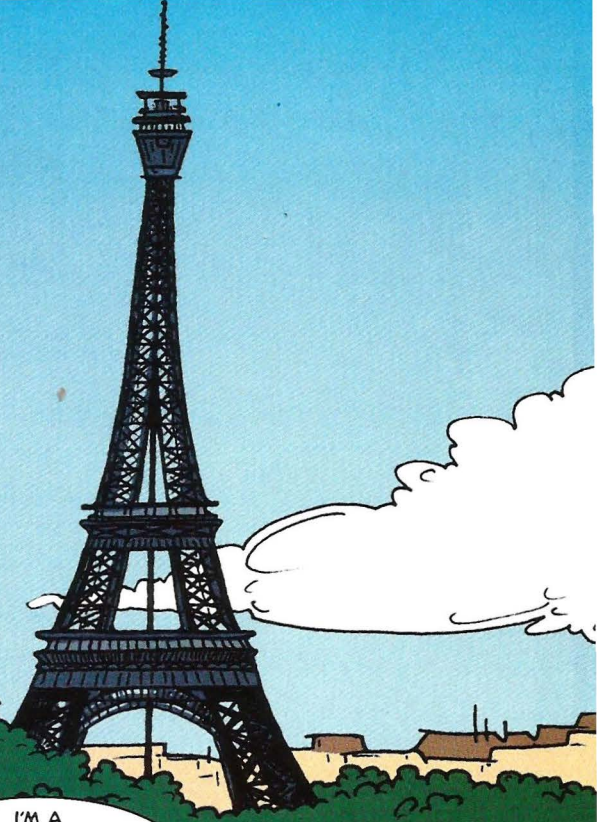

THAT'S BECAUSE I'M A NATURALIZED AMERICAN.

OH?

I'M A SRELKIT NERB. AT LEAST THAT'S WHAT WE USED TO BE CALLED BEFORE THE INVADERS WIPED US OUT.

ALL OF YOUR COUNTRYMEN WERE MASSACRED? THAT IS SO SAD. HAVE YOU NO FAMILY? NO BROTHER OR SISTER?

OKAY.

I'VE ONLY GOT MY YOUNGER BROTHER MARK. WE DON'T SPEAK MUCH.

I CAN SEE THAT YOU CARRY MANY SORROWS IN YOUR HEART. LET ME EASE YOUR PAIN, IF ONLY FOR JUST ONE NIGHT.

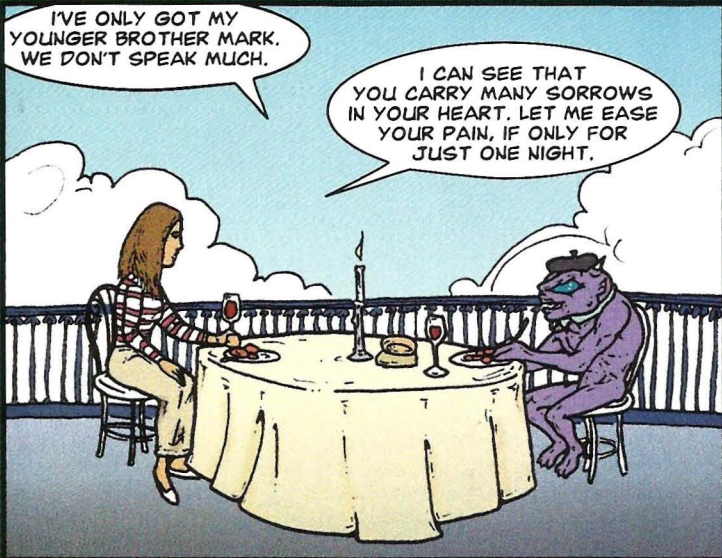

JOURNAL ENTRY #864652:
I'M SOOO BORED! THERE IS NOTHING
WORSE THAN HAVING A REAL JOB.

WHEN I WAS HUSTLING ANTI-MATTER
FOR THE SOG MUKKERS, NOBODY
TOLD ME WHAT TO DO.

NOW LOOK AT ME, WORKING FOR THE MAN, PUNCHING
A TIME CLOCK LIKE ALL THE OTHER SUCKERS.

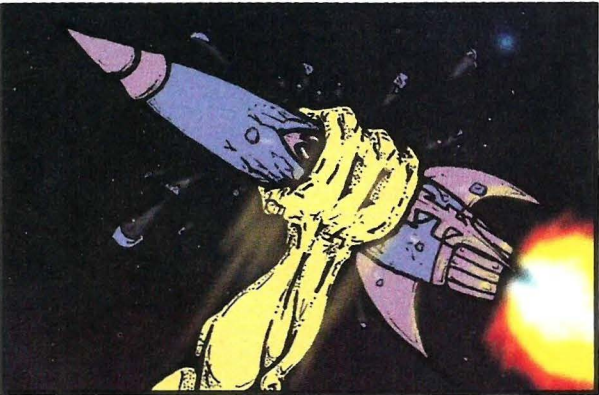
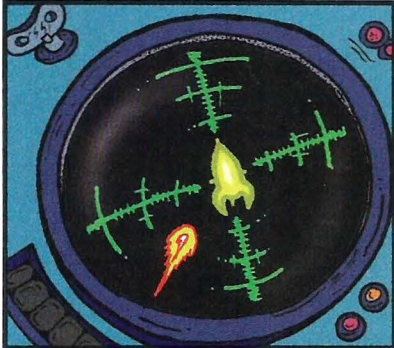

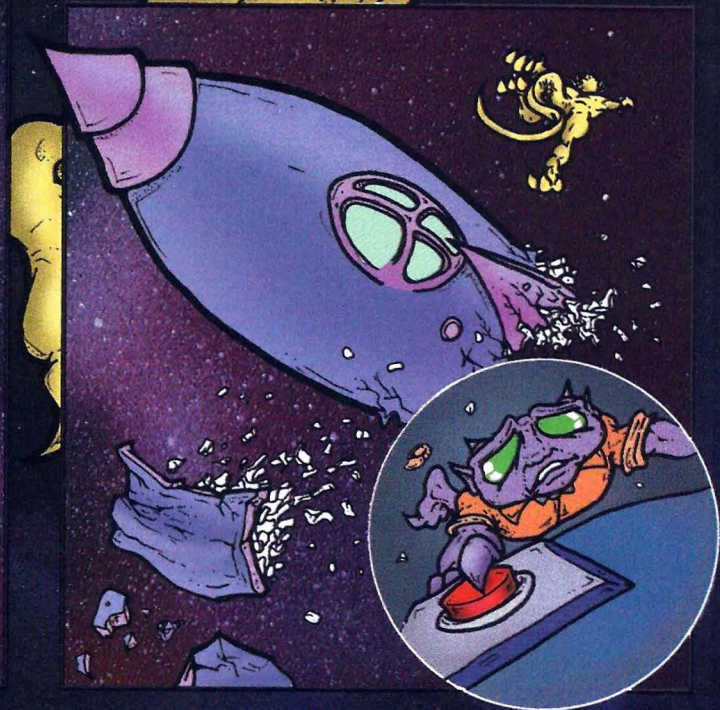

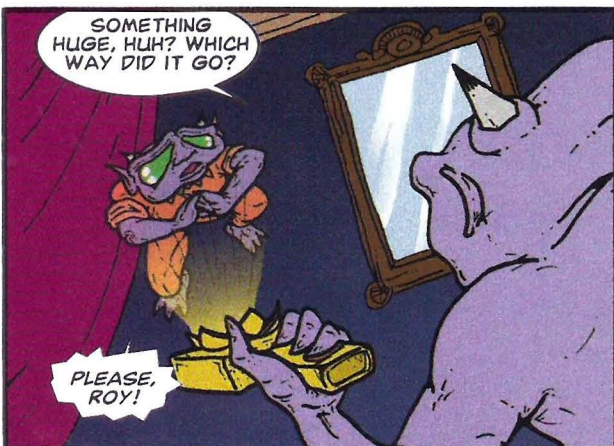
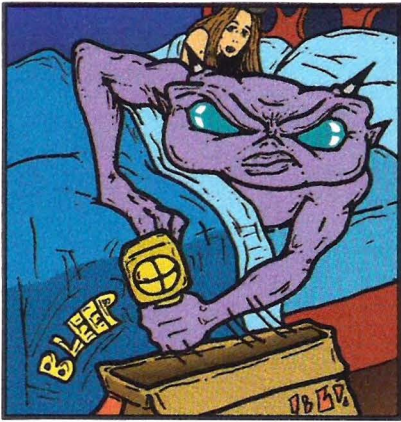
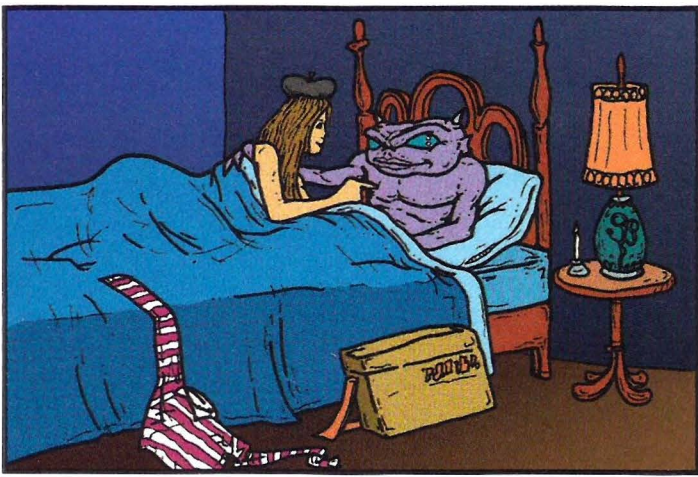

YOU MUST HELP YOUR BROTHER. I WILL WAIT FOR YOU, MY DARLING.



DAMN IT, MARK! YOU'RE A PAIN IN MY ASS.



JIM, I HAVE SOMETHING TO TELL YOU.



NO. THAT'S NO GOOD.

LISTEN, JIM. WE NEED TO DISCUSS SOMETHING THAT-



AW, CRAP. HOW AM I SUPPOSED TO TELL HIM ANYTHING?



EVER SINCE ROY LEFT HE'S BEEN SUCH AN OBNOXIOUS, SELF-DESTRUCTIVE JERK.



NOT EXACTLY "DADDY" MATERIAL.



HI JIM. IT'S ME

M-MADELINE?

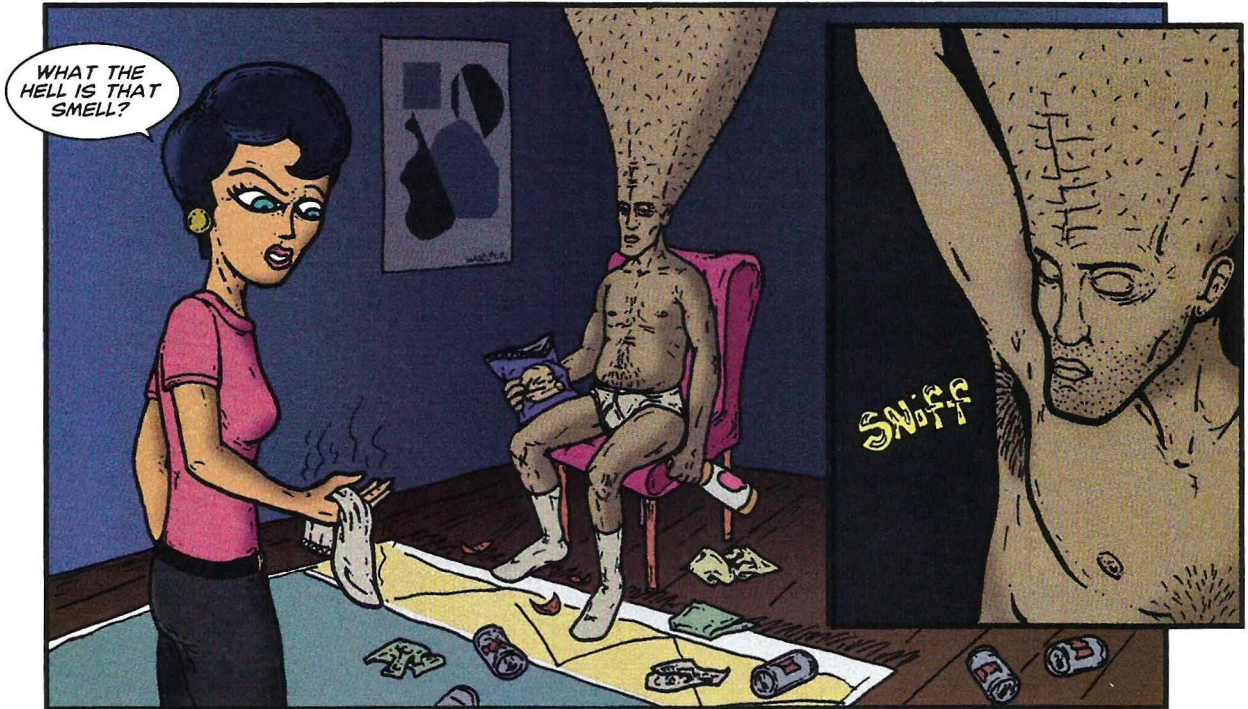

WHAT THE HELL IS THAT SMELL?

SNIFF

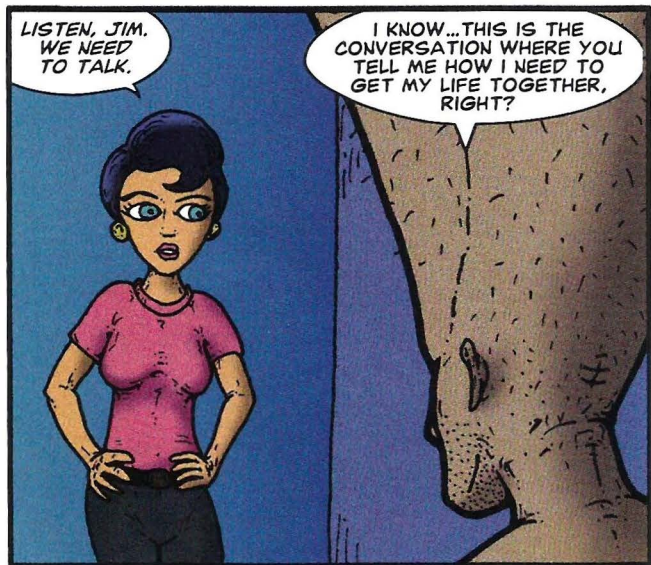

LISTEN, JIM. WE NEED TO TALK.

I KNOW...THIS IS THE CONVERSATION WHERE YOU TELL ME HOW I NEED TO GET MY LIFE TOGETHER, RIGHT?

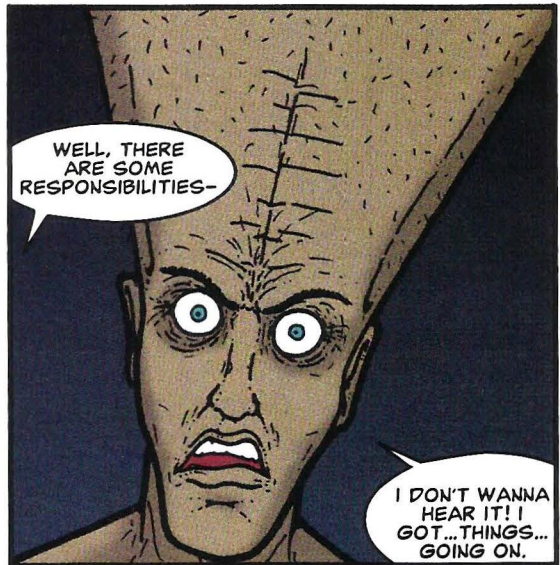

WELL, THERE ARE SOME RESPONSIBILITIES-

I DON'T WANNA HEAR IT! I GOT...THINGS... GOING ON.

I DIDN'T COME HERE TO FIGHT. I'M TRYING TO TELL YOU SOMETHING.

AW, GREAT! YOU'RE SEEING SOMEONE ELSE, RIGHT? WHO IS HE?

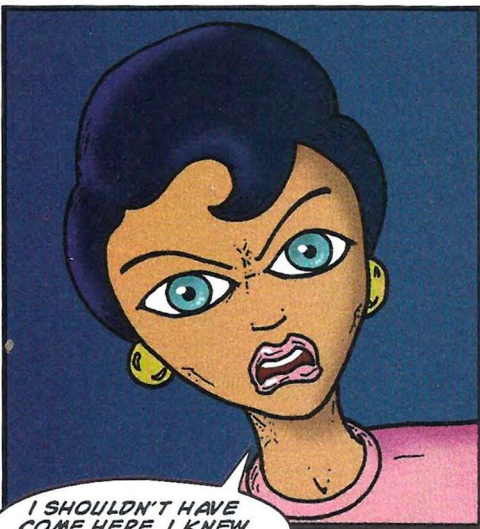

I SHOULDN'T HAVE COME HERE. I KNEW I COULDN'T TALK TO YOU.



GOODBYE, JIM.

NO! WAIT!

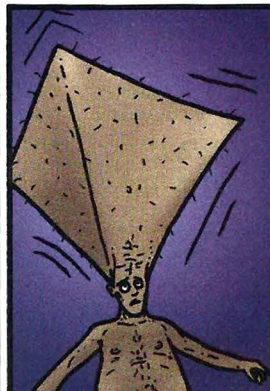
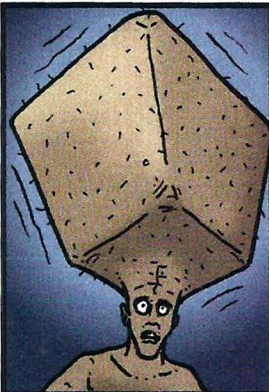

JOURNAL ENTRY #864653. WELL...
I'M NOT BORED ANYMORE.

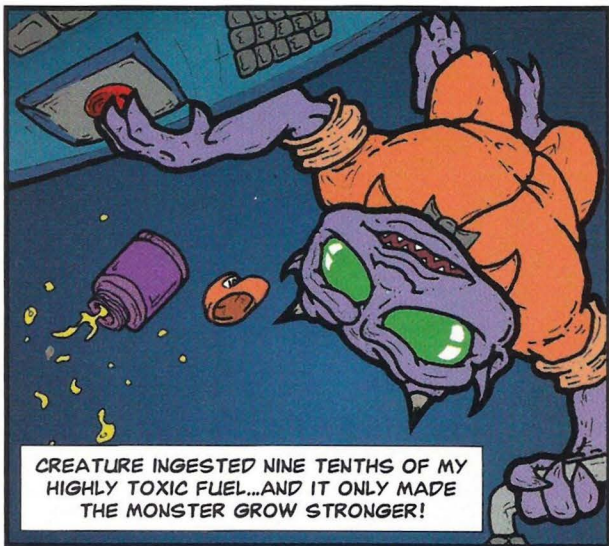

CREATURE INGESTED NINE TENTHS OF MY
HIGHLY TOXIC FUEL...AND IT ONLY MADE
THE MONSTER GROW STRONGER!

I'VE GOT ABOUT A DAY
LEFT TO ME NOW.

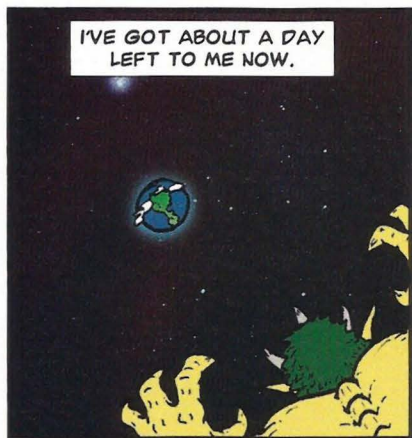

TWO IF I'M LUCKY.

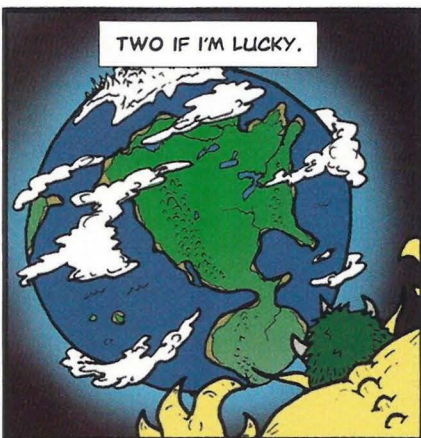

AS FOR THAT CREATURE...

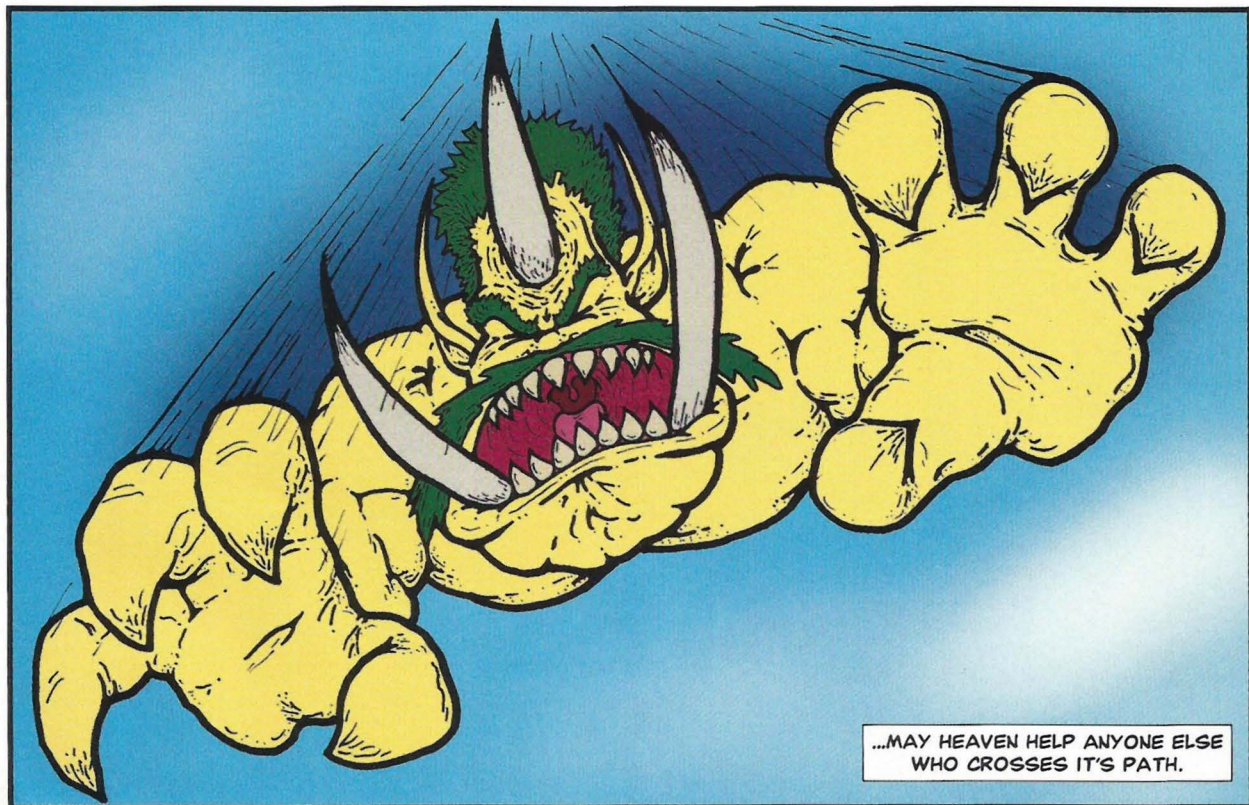

...MAY HEAVEN HELP ANYONE ELSE
WHO CROSSES ITS PATH.

WHAT'S IN ROY'S BAG?



Fig. A

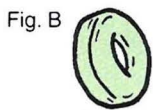

Fig. B



Fig. C

BREATH MINTS

Whether touring Europe or a distant nebula, the well-traveled Srelkit Nerb is always prepared with fresh breath... especially when looking for love.

HOLOGRAPHIC COMMUNICATOR

A direct link into the Galactic-Wide Web. This device allows instant universal communication without the annoying delays associated with conventional light speed transmissions. Other features include caller i.d. and 3-way conferencing.

63.32mm

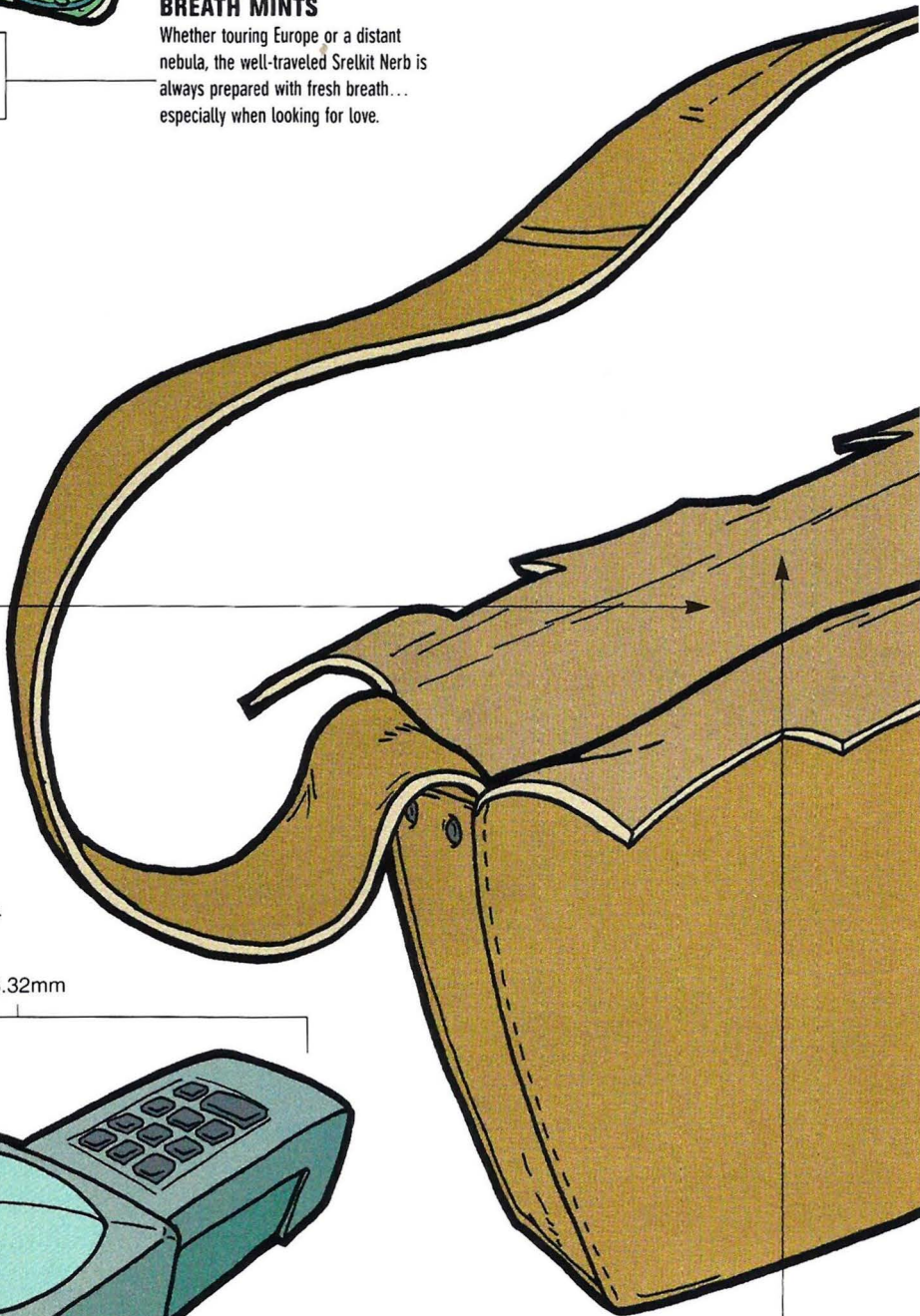
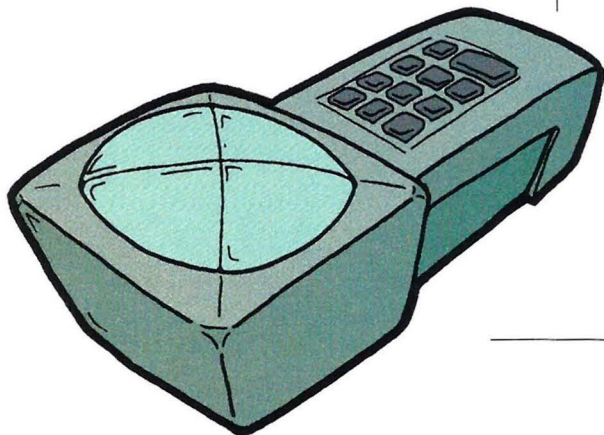

THE GEMSTONE

One of the five pieces used to build the anti-invasion machine, the stone is mined on Beta V, an asteroid within the Antares Nebula. Its scientific name is uvarium but it is commonly referred to as "fire ore." It is, to put it simply, crystallized energy.

NOTE: When not in use, fire ore should be encased in lead.

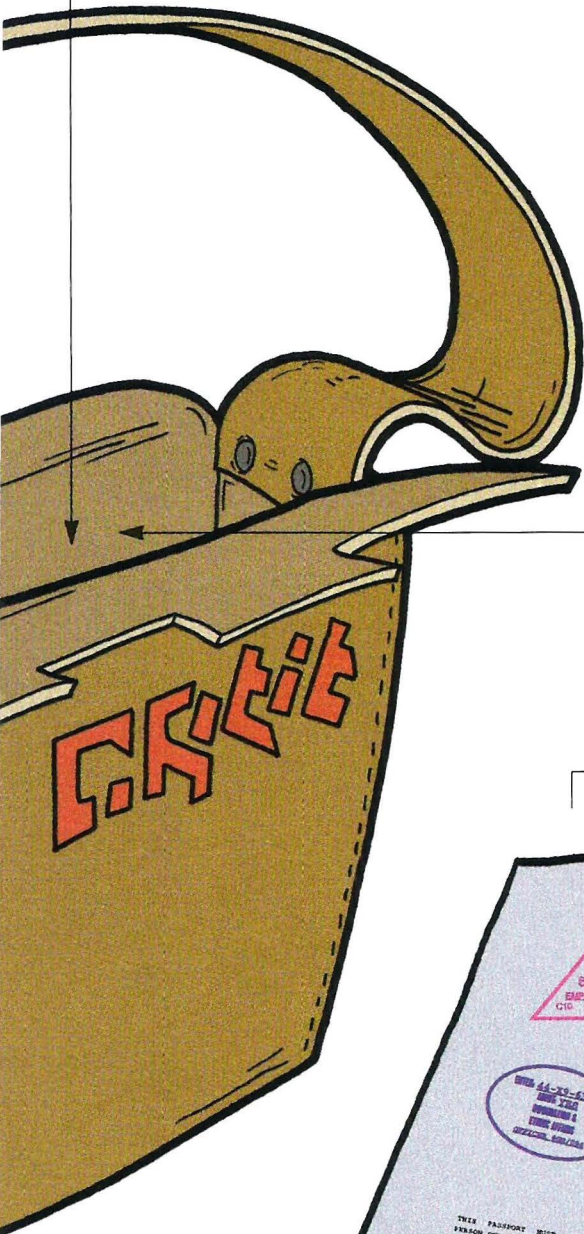
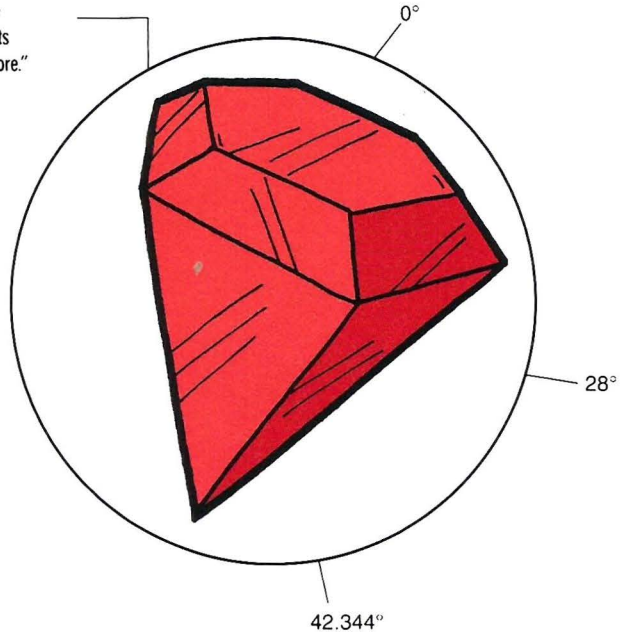

PASSPORT

Always remember to have your passport ready at the gate, otherwise you may be hassled by the man.

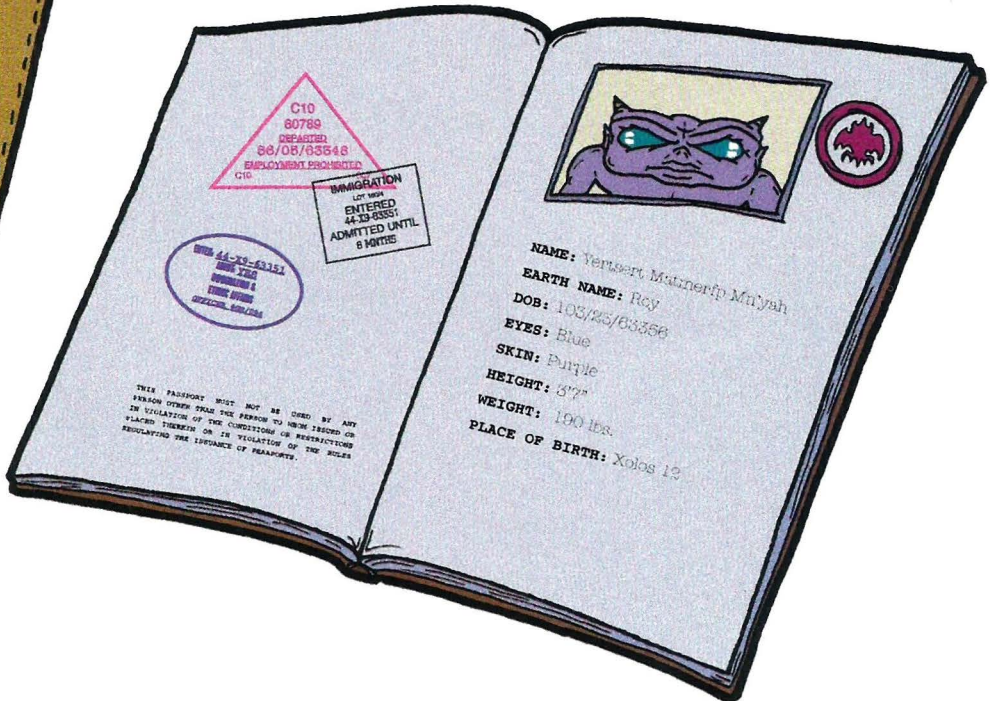

JIM, I'M HOME.
AND I GOT
YOU A GREAT
SOUVENIER.

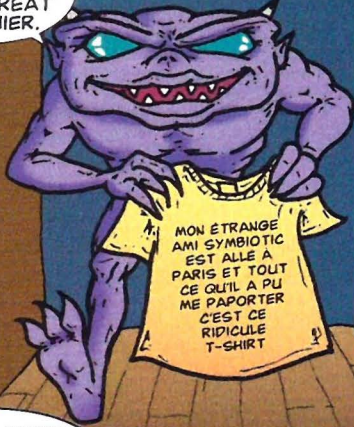

WHAT'S THAT SMELL?



LUUUHHHHHHNNNN

ARE YOU OKAY?
WHAT'S WRONG
WITH YOU?



I HAD A FIGHT WITH
MADELINE...AND MY HEAD
STARTED GOING NUTS.

WHAT ARE
YOU DOING BACK IN THE
CITY? I THOUGHT YOU
WERE STILL TOURING
AROUND EUROPE.



YEAH, WELL,
I GOT THIS CALL
FROM MARK. IT
LOOKS LIKE--

CRASH!
AAAAAAAAAAAAAAAAAAAA

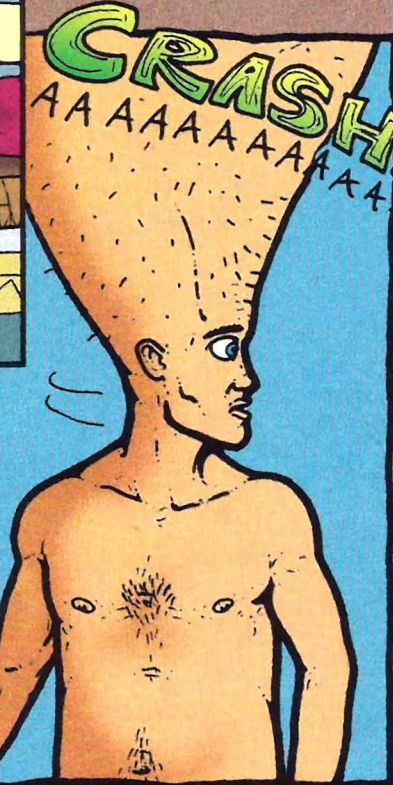

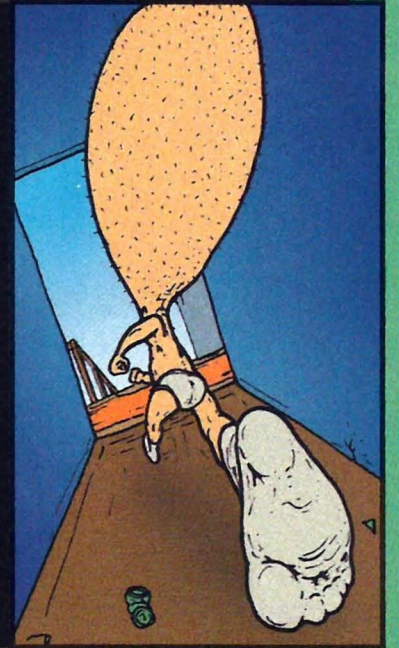
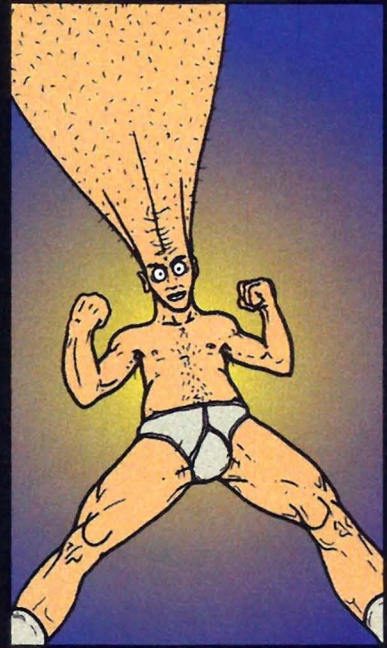

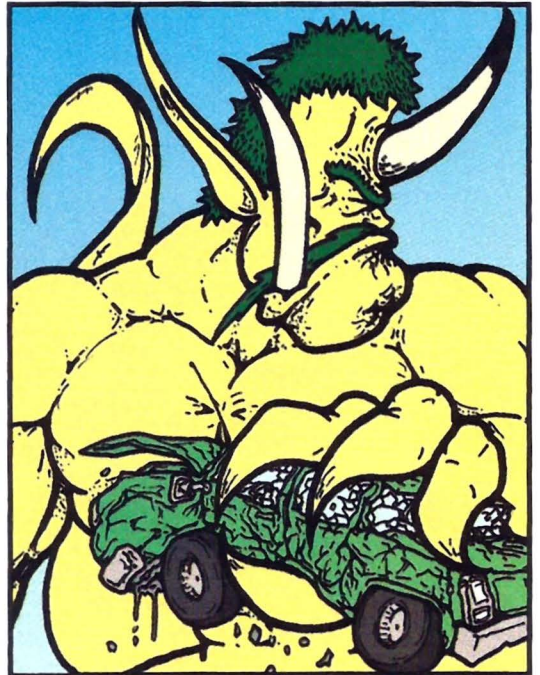
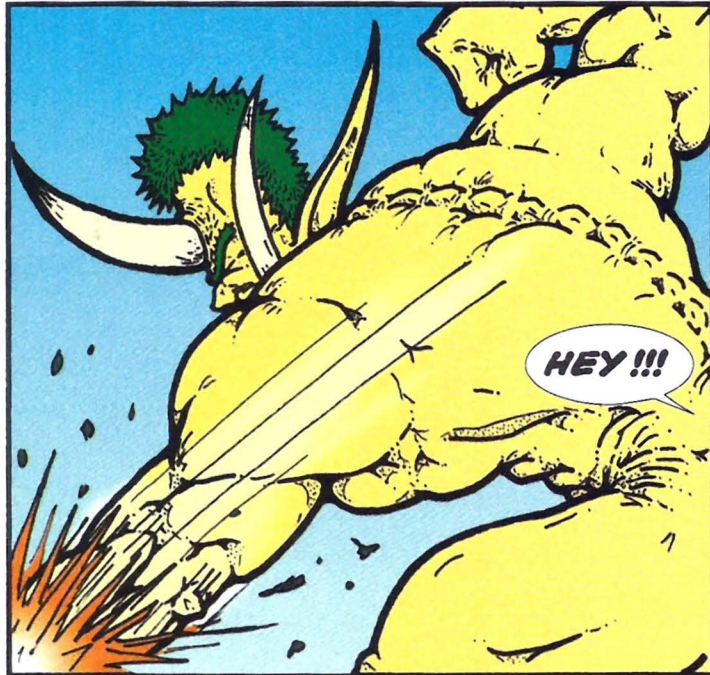
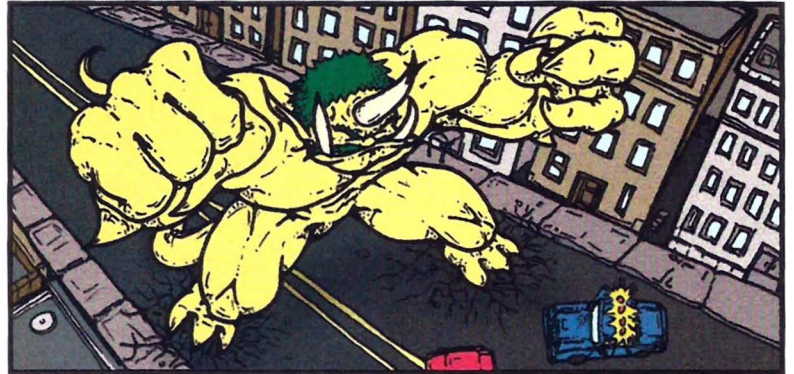
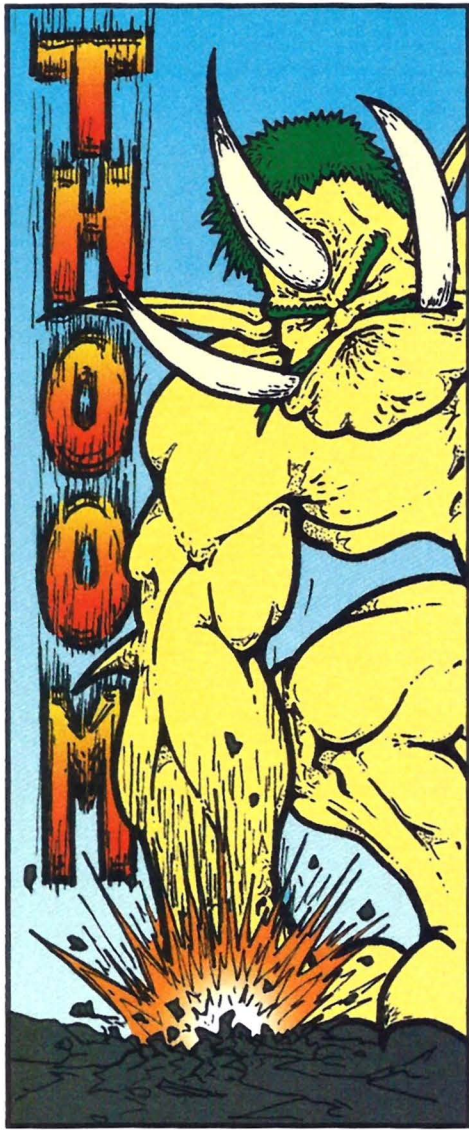

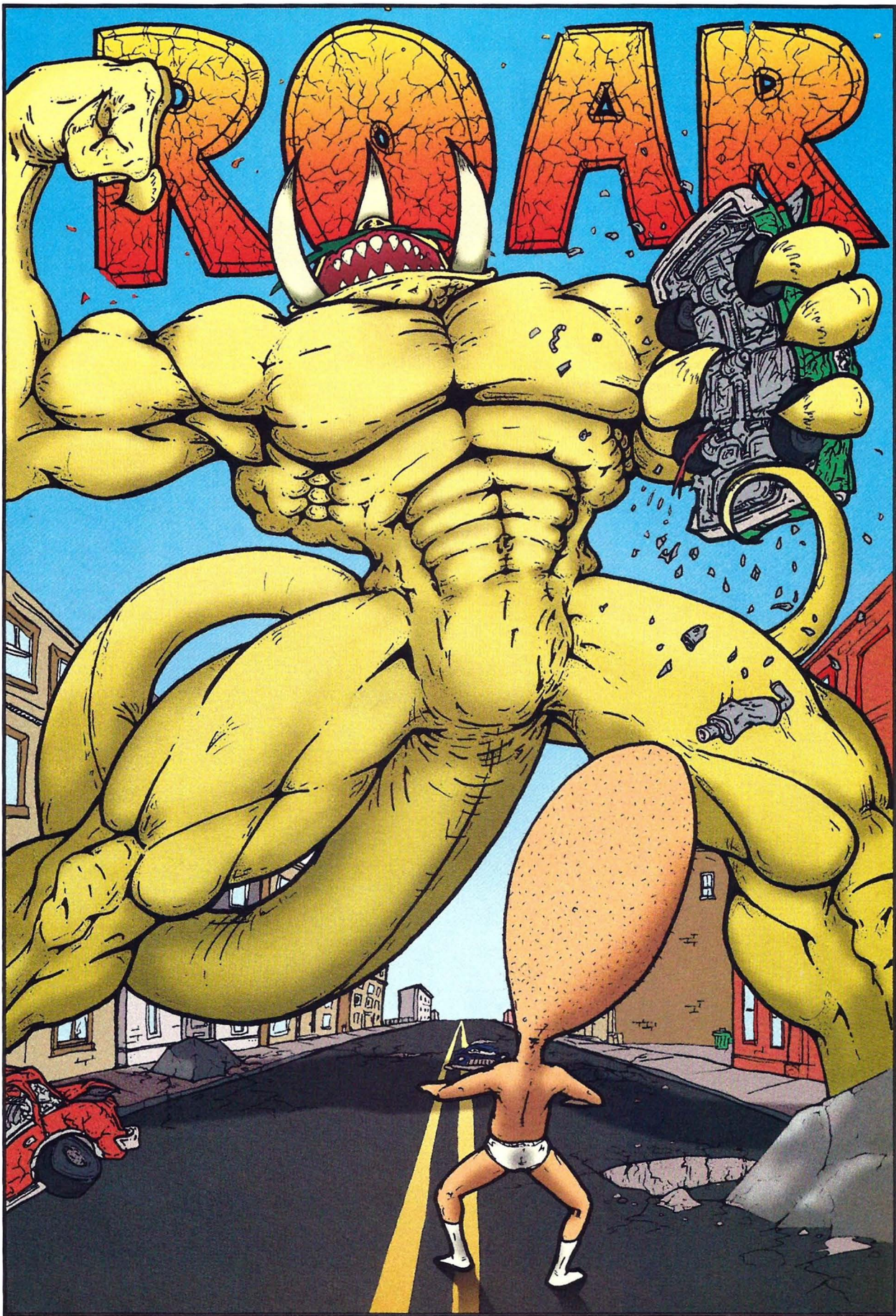

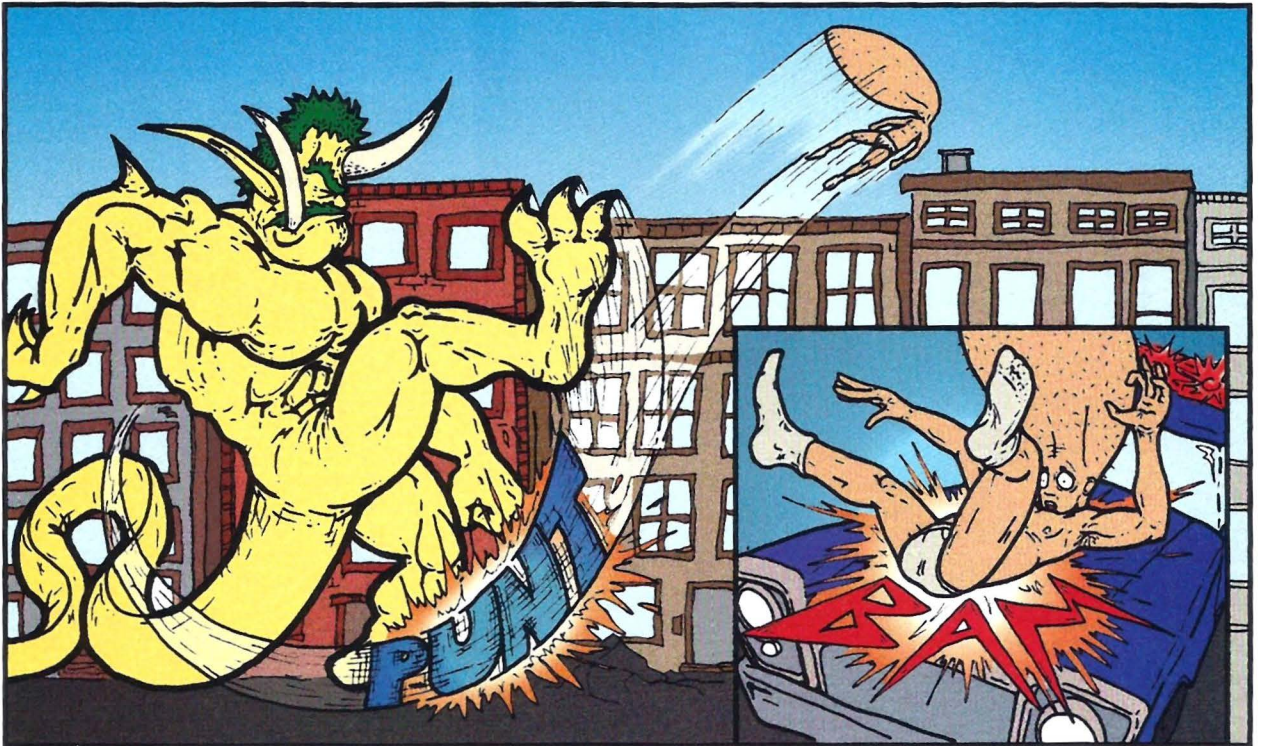
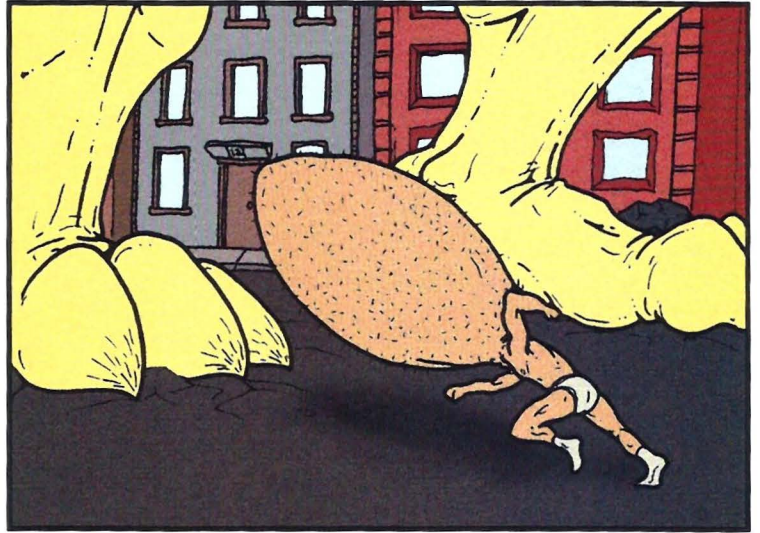
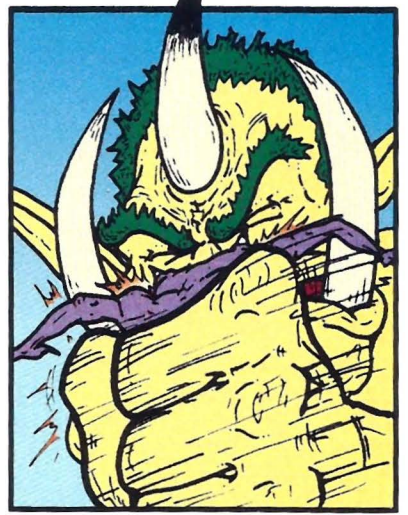
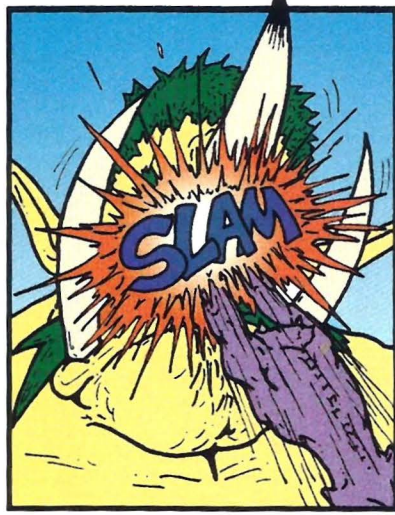
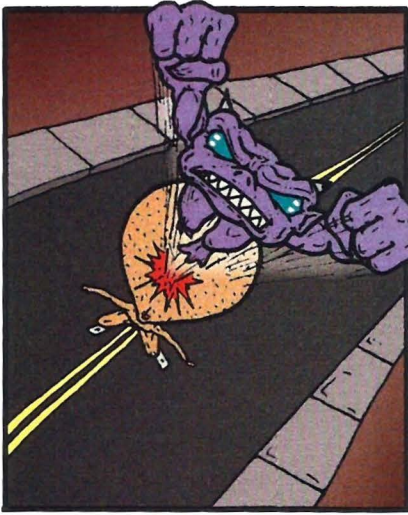

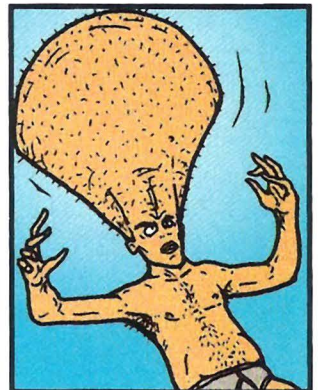
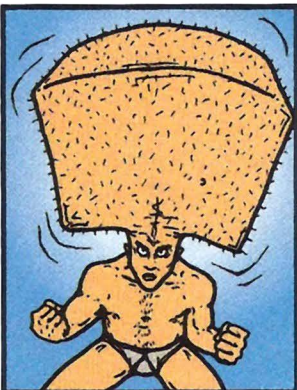
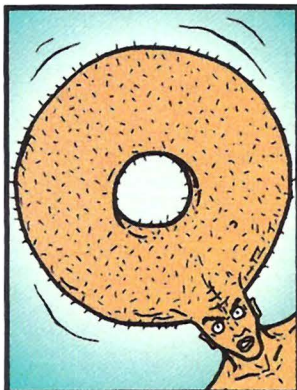
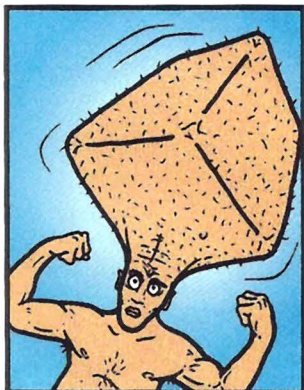
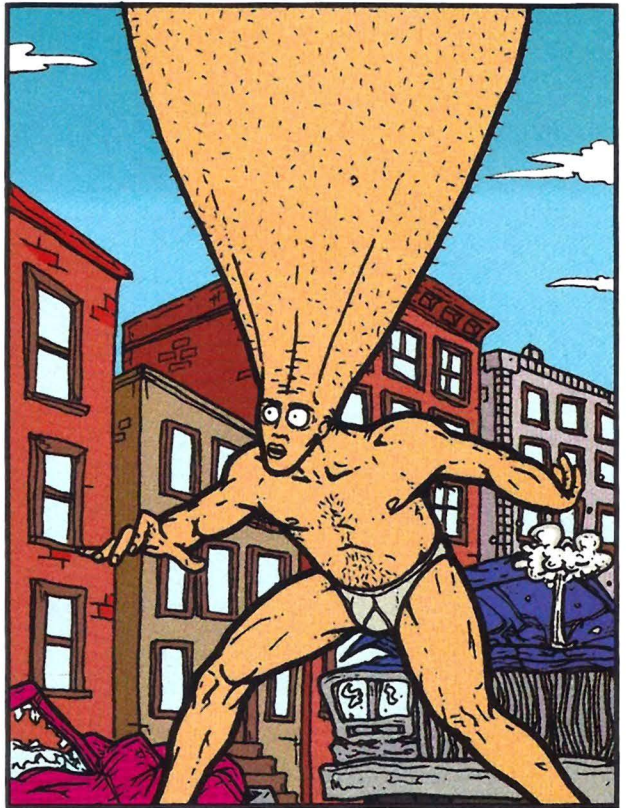
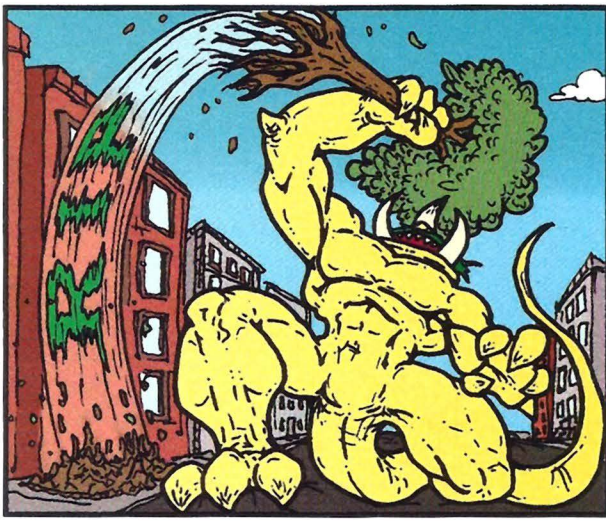

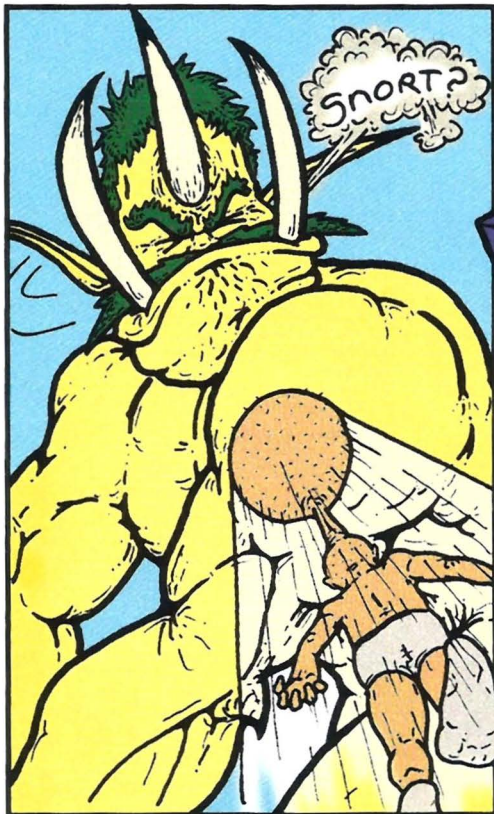
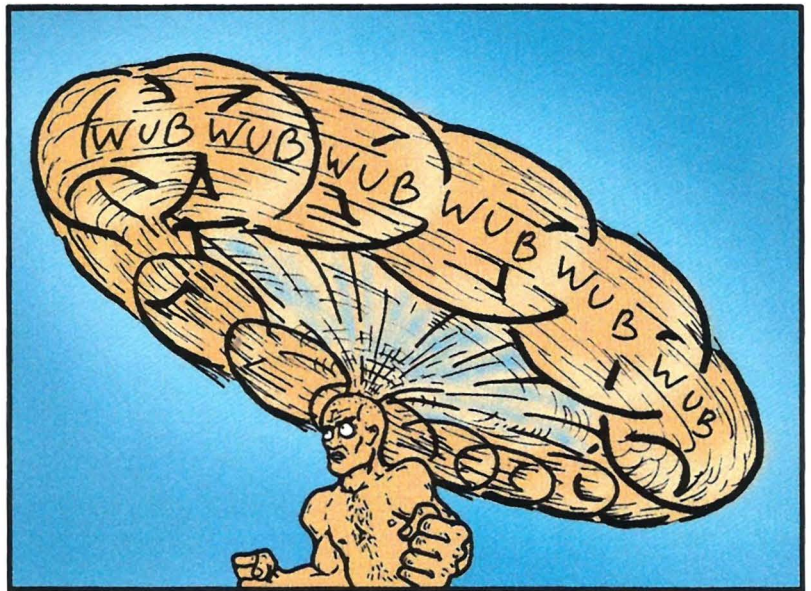
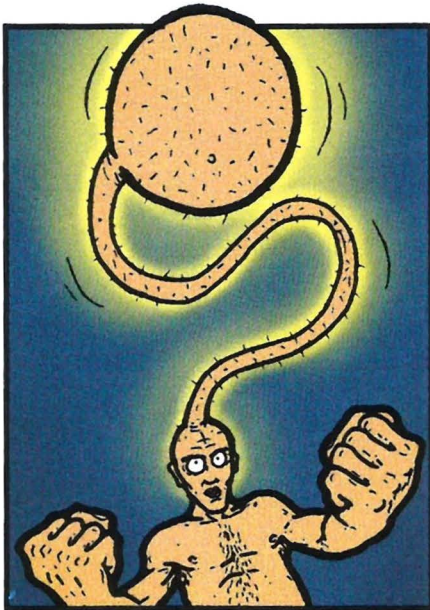

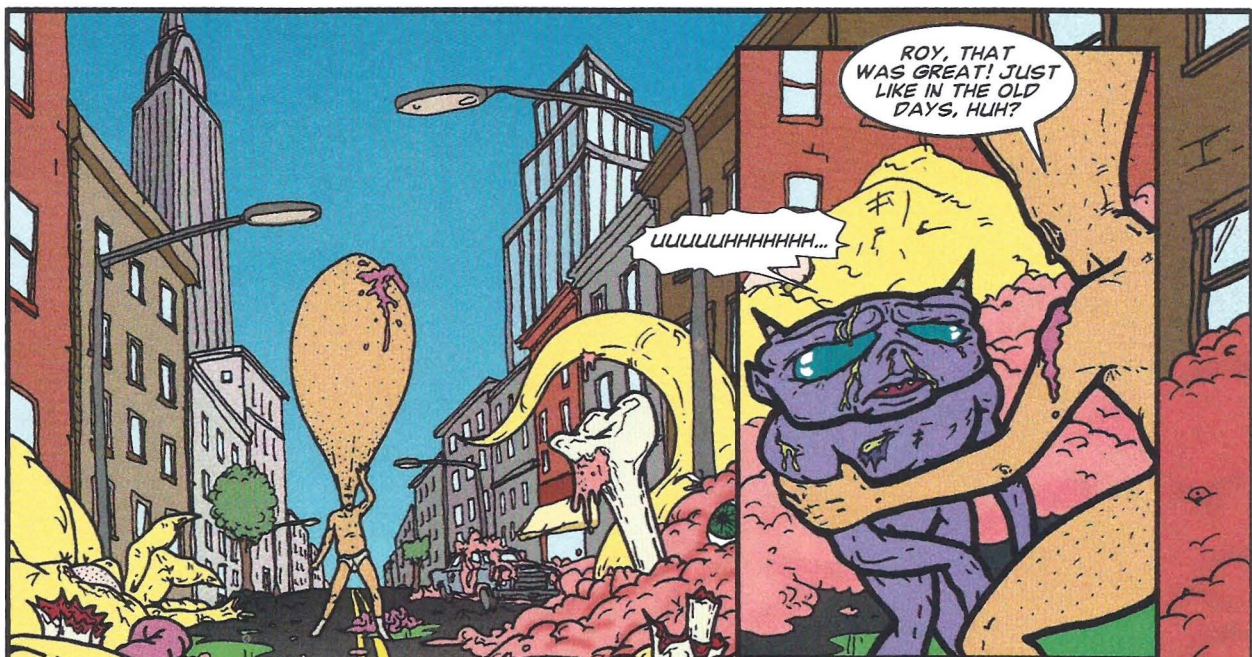

ROY, THAT WAS GREAT! JUST LIKE IN THE OLD DAYS, HUH?

UUUUUUHHHHHHH...



SO WHAT WAS IT YOU WERE SAYING BEFORE? SOMETHING ABOUT A MISSION TO SAVE YOUR BROTHER?



OH, YEAH. HE'S TRAPPED IN OUTER SPACE AND WE NEED TO SAVE HIM.



I'LL NEED TO TAKE A SHOWER.







CHAPTER TWO

UPWARD MOBILITY



I CAN STILL TASTE THE SUCCULENT FLAVOR OF HIS SHRIMP SPECIALTY.

SHRIMP
\$8.99 /lb.



STOP THINKING ABOUT HIM. IT ONLY MAKES THINGS WORSE.

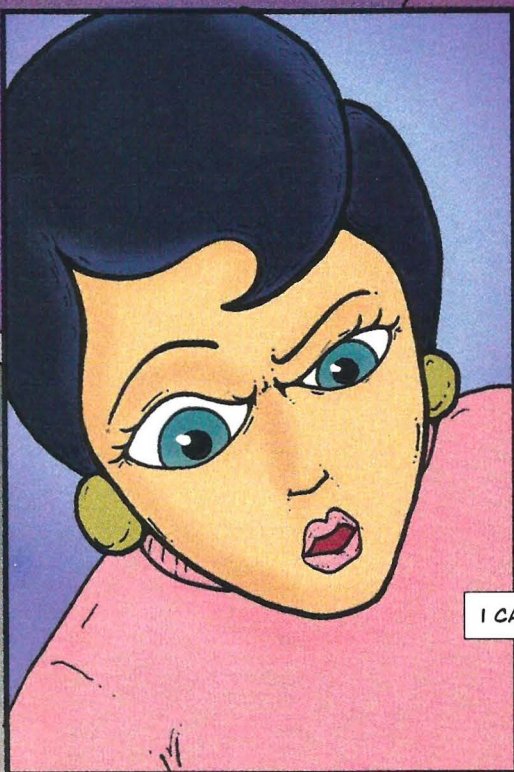
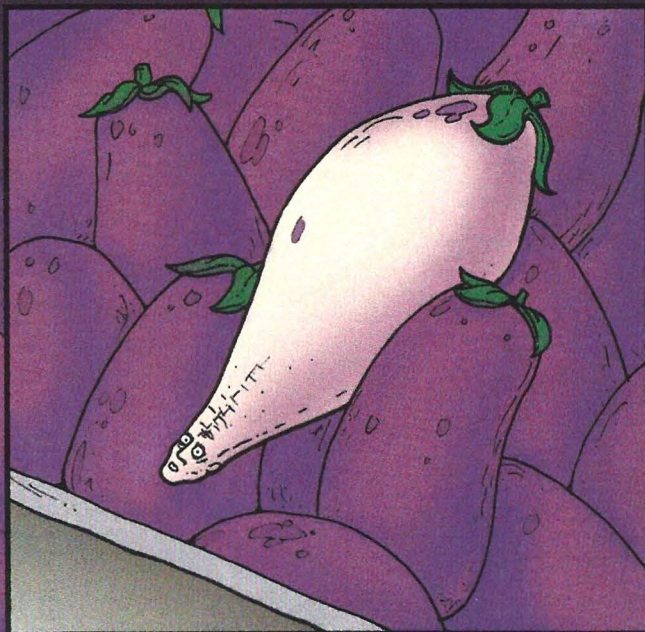

I CAN'T GET HIM OUT OF MY MIND!

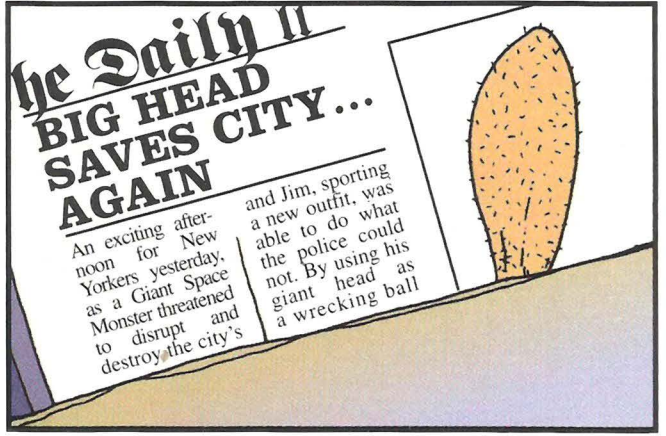

I CAN'T BELIEVE THAT HE-

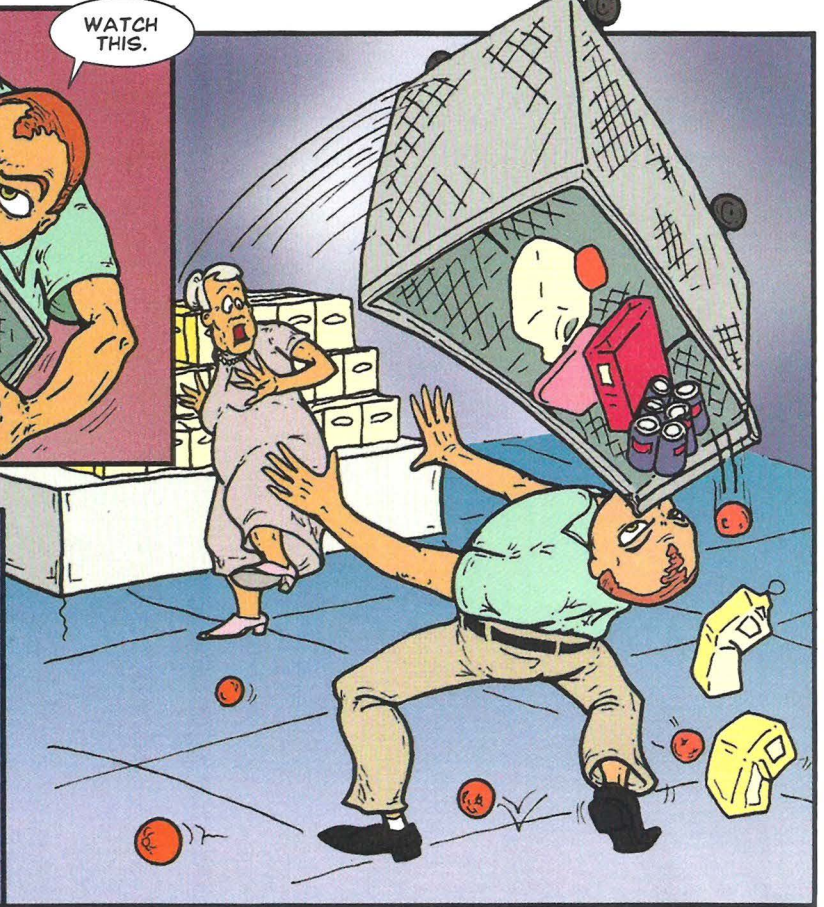
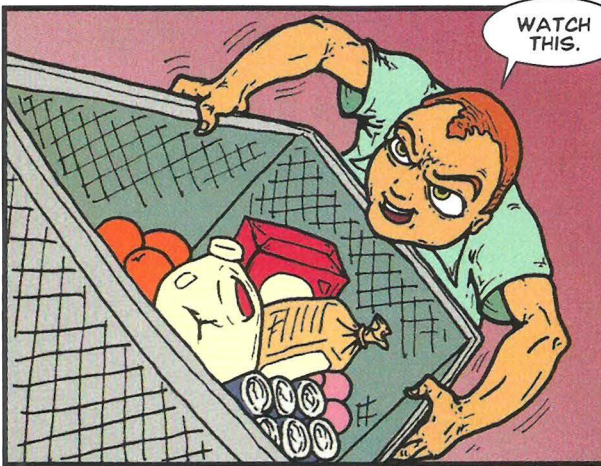

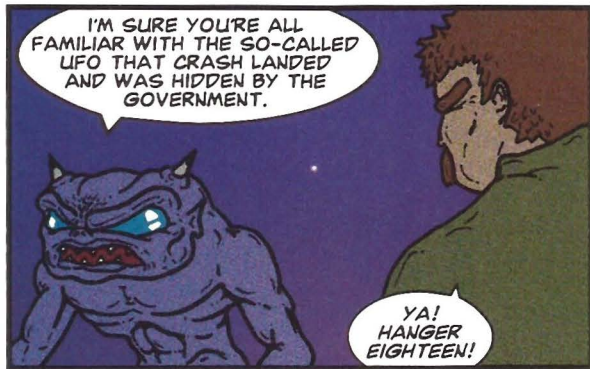
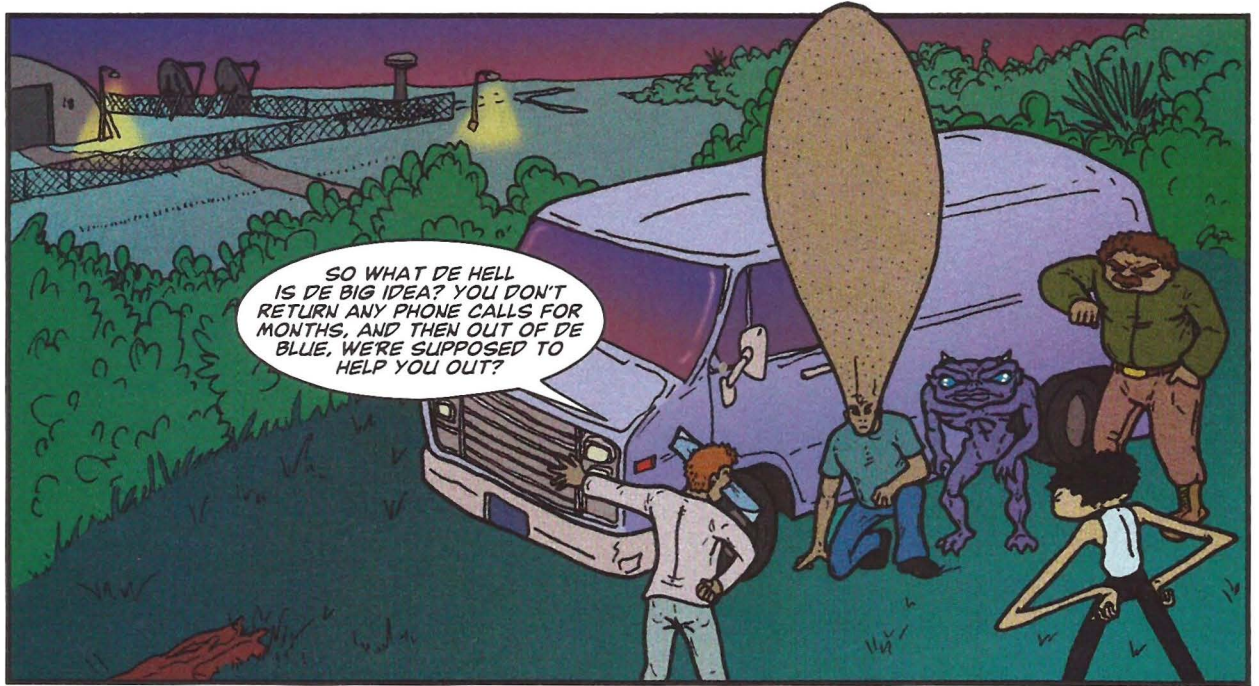



...AND THEN I JUST HAD TO ASK MYSELF ...AM I BETTER OFF WITH HIM OR WITHOUT HIM?

WELL, I THINK YOU DID THE RIGHT THING. IT'S SO EASY TO GET TRAPPED IN A BAD SITUATION.



YOU KNOW, NED, I DON'T USUALLY OPEN UP LIKE THIS TO TOTAL STRANGERS... BUT I FEEL SOMEHOW... CONNECTED. THANKS FOR LISTENING.

MY PLEASURE.

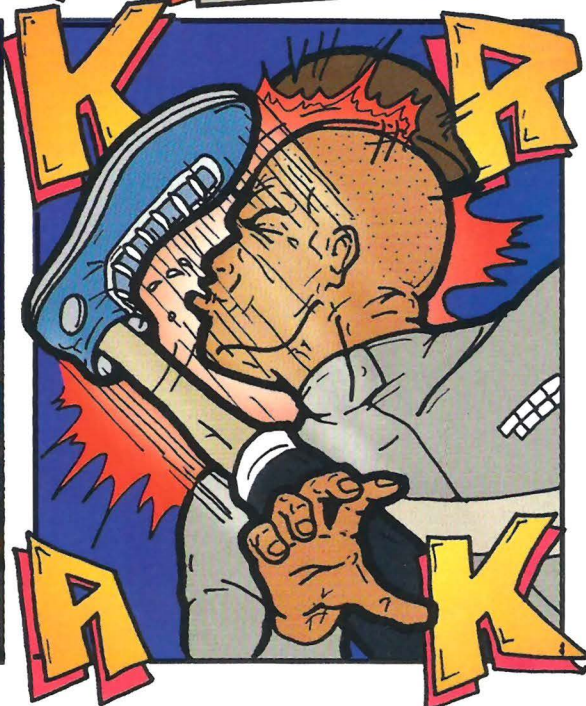
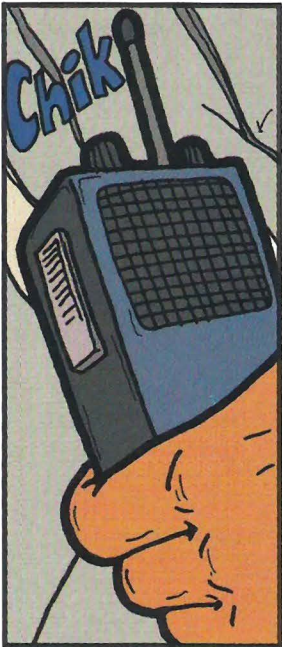



GOLDEN SPIDAAAAAAA!!!!

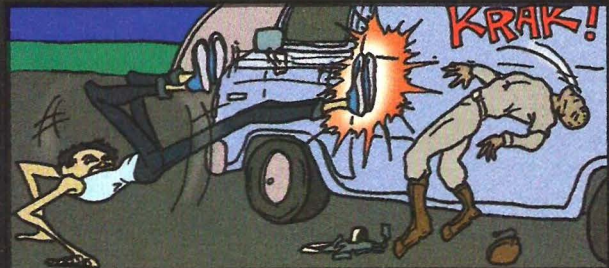
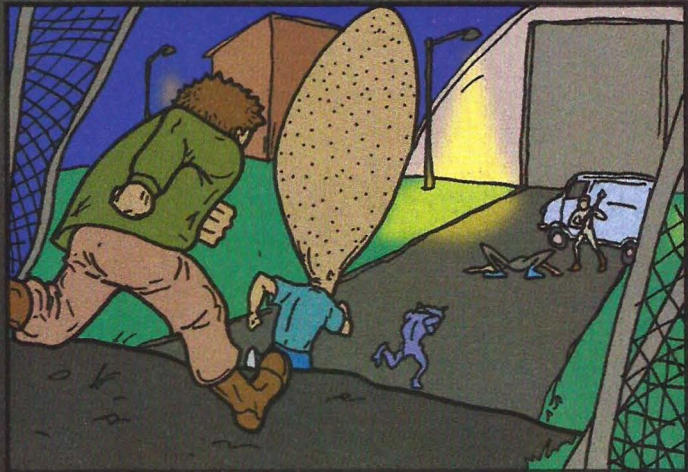

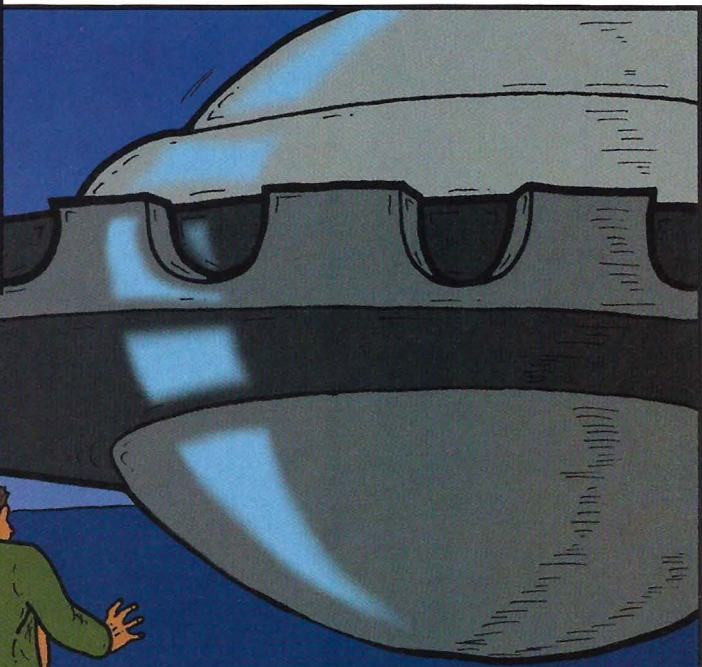
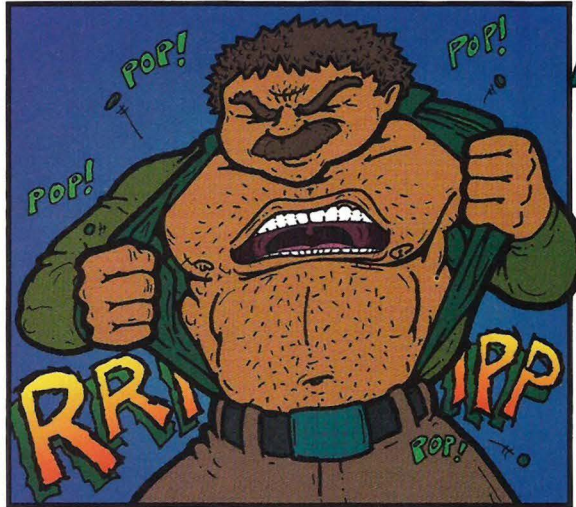
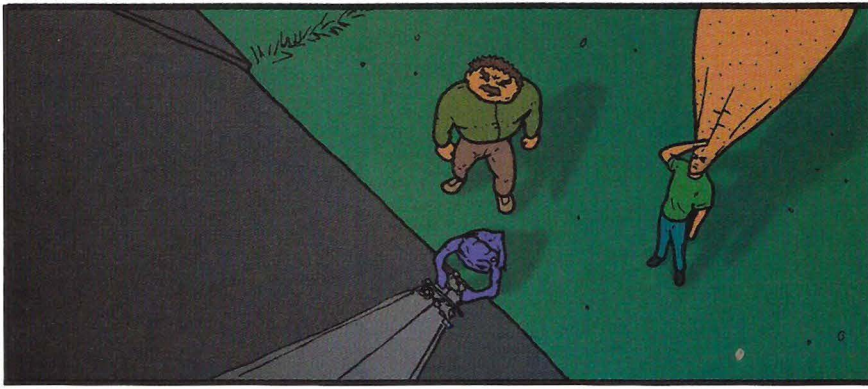



WELL, IT'S BEEN A LOVELY EVENING, BUT I REALLY HAVE TO GET BACK TO MY PROJECT.

PROJECT?



YEAH, I'VE TAKEN UP WELDING. I'VE GOT SOME SHEET METAL AND I...IT'S JUST SORT OF A HOBBY.

I STUDIED ARC WELDING IN TRADE SCHOOL!



WOULD YOU LIKE TO COME ON UP AND TAKE A LOOK?

SURE!

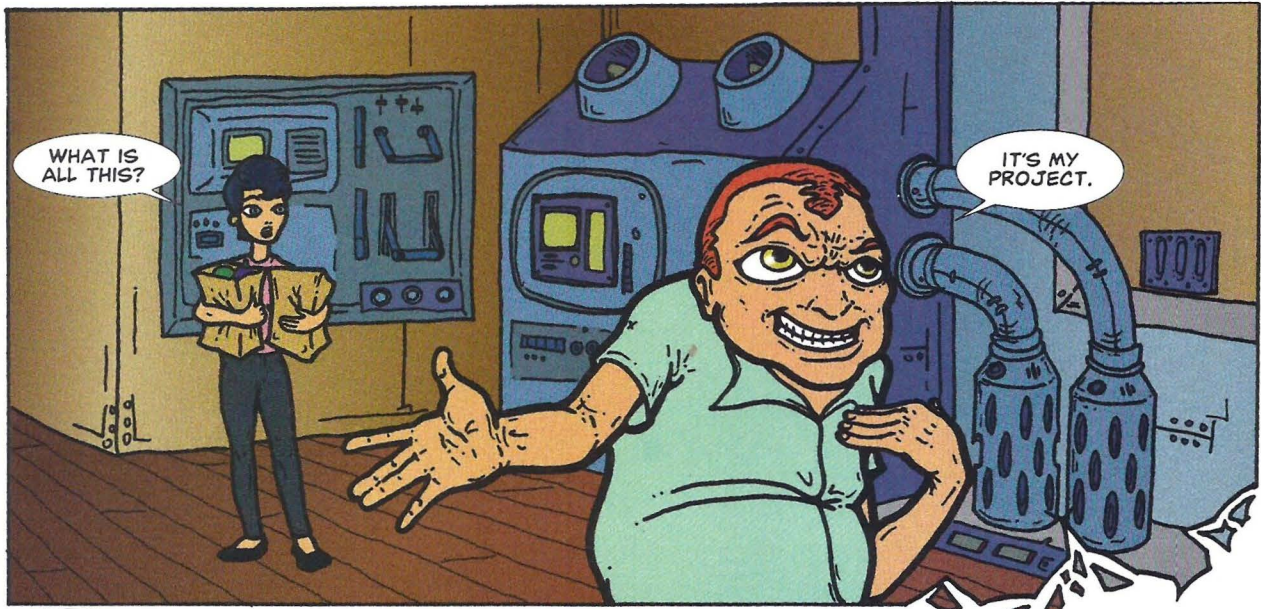

WHAT IS ALL THIS?

IT'S MY PROJECT.



PRETTY ELABORATE. HOW WERE YOU ABLE TO-



MADLINE, THERE'S SOMETHING YOU NEED TO KNOW.

OH... YOU'RE NOT GONNA HIT ON ME ARE YOU?

I THOUGHT YOU'D NEVER ASK.





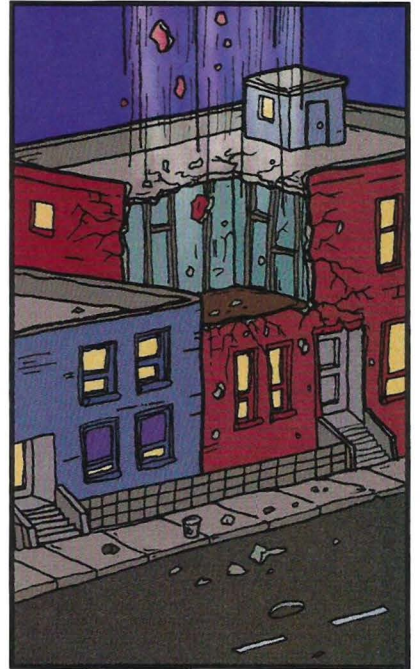
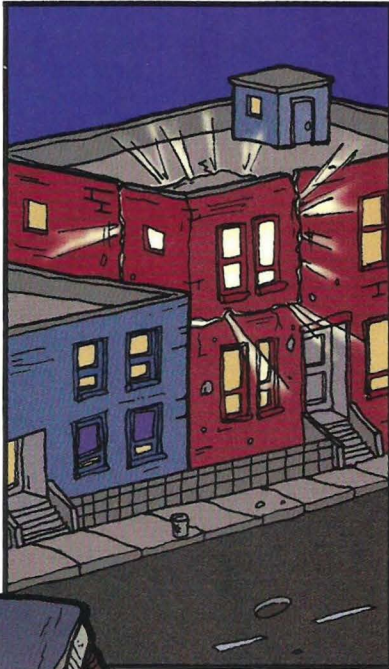
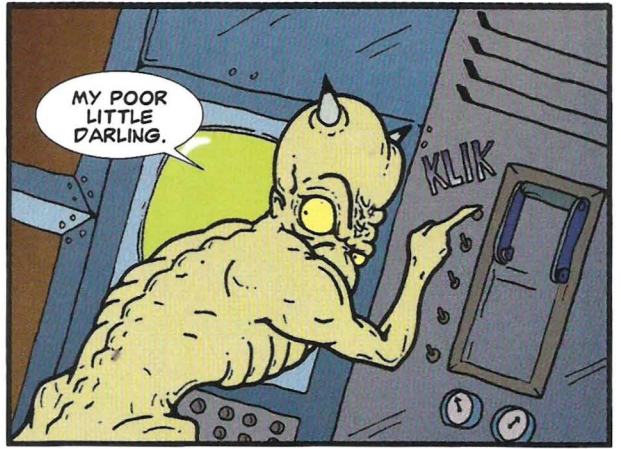



YA! COAST IS CLEAR!



OKAY... BRING HER OUT...NICE AND STEADY



THANKS FOR YOUR HELP, GUYS. I COULDN'T HAVE DONE THIS WITHOUT YOU.



YA! YOU GO SAVE BROTHER.



NOW GET DE HELL OUT OF HERE!



VOOOOOOMM!



JOURNAL ENTRY #864564: THE STALKING APPROACH OF DEATH BRINGS ABOUT MOMENTS OF QUIET REFLECTION.



LOOKING BACK, I SEE ALL THE MISSED OPPORTUNITIES. THE BAD CHOICES. TIMES I COULD HAVE MADE A DIFFERENCE, BUT DIDN'T.



DISTRESS SIGNAL...UNANSWERED. IF ONLY...



...ONE MORE CHANCE.



MARK!!

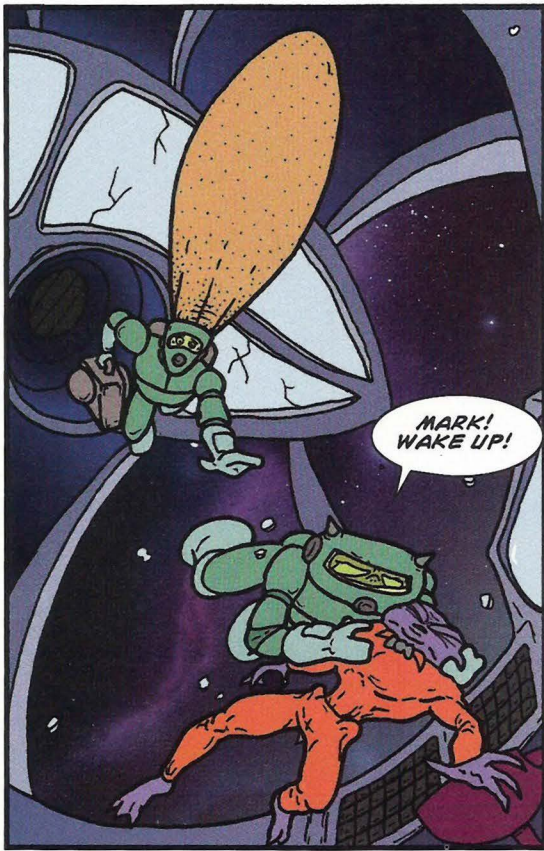

MARK!
WAKE UP!

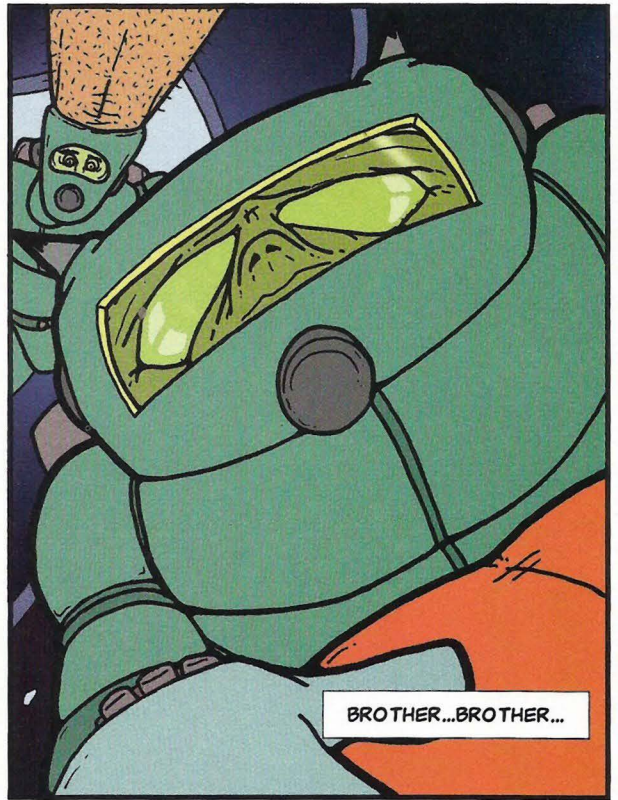

BROTHER...BROTHER...

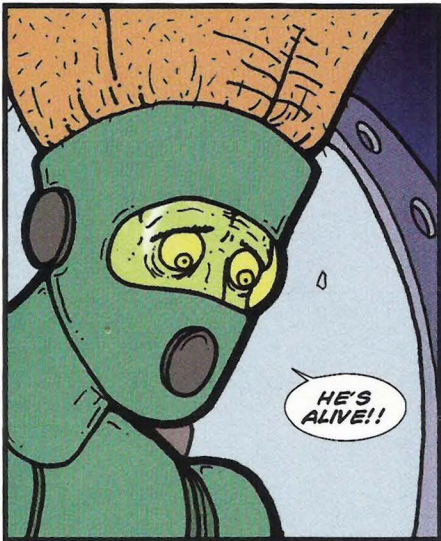

HE'S
ALIVE!!



BREATHE, MARK.
BREATHE!



...WILL MAKE YOU PROUD THIS TIME.

THIS IS GORK
CALLING K-NAR. DO YOU
READ ME, K-NAR. COME IN,
OVER.



GORK! WHY ARE
YOU CALLING ME?
I THOUGHT YOU WERE
BANISHED FOR LIFE?

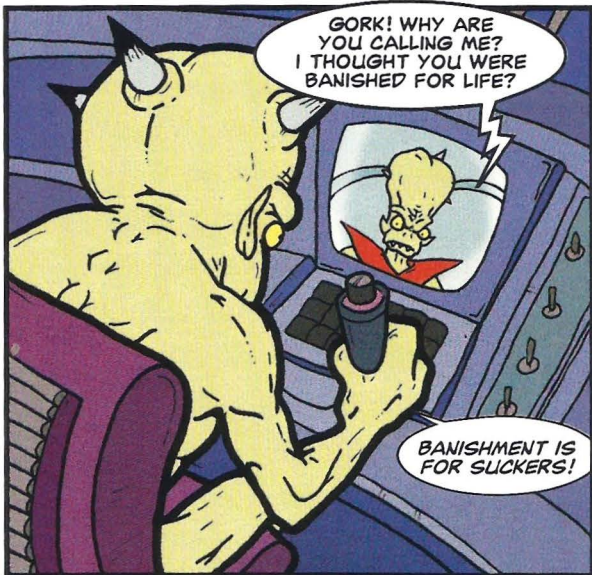

BANISHMENT IS
FOR SUCKERS!

I'M COMING BACK
AND I'VE GOT A
PLAN THAT'LL PUT
THE PARASITES
BACK ON TOP.

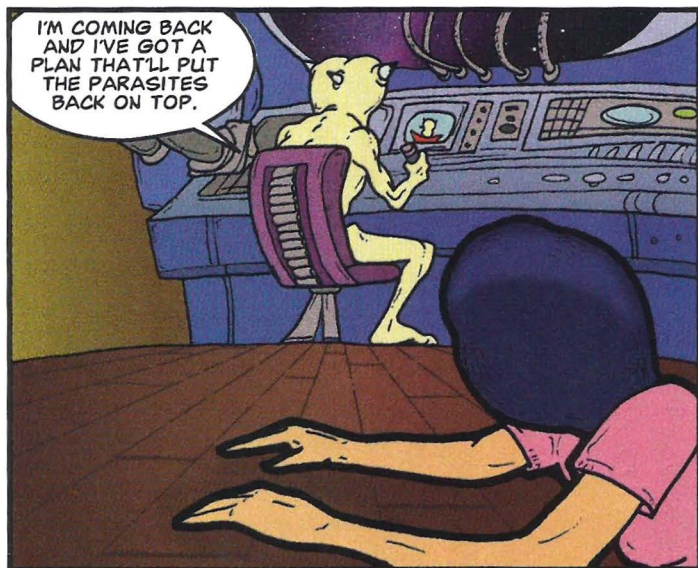

WHUT?!

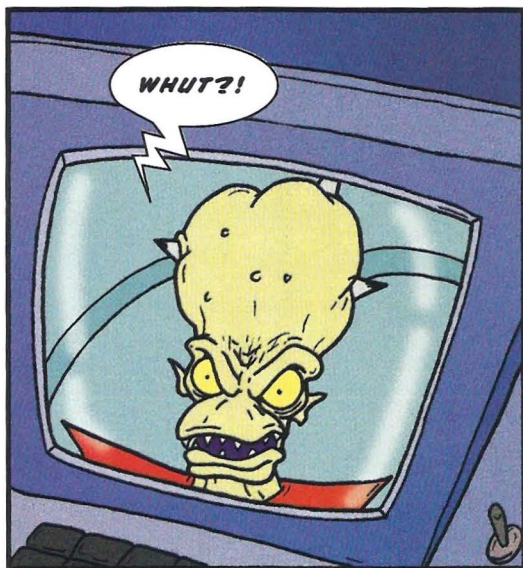

I'VE MANAGED TO
PROCLURE A HUMANOID
FEMALE...AND SHE IS
WITH CHILD!

GASP!

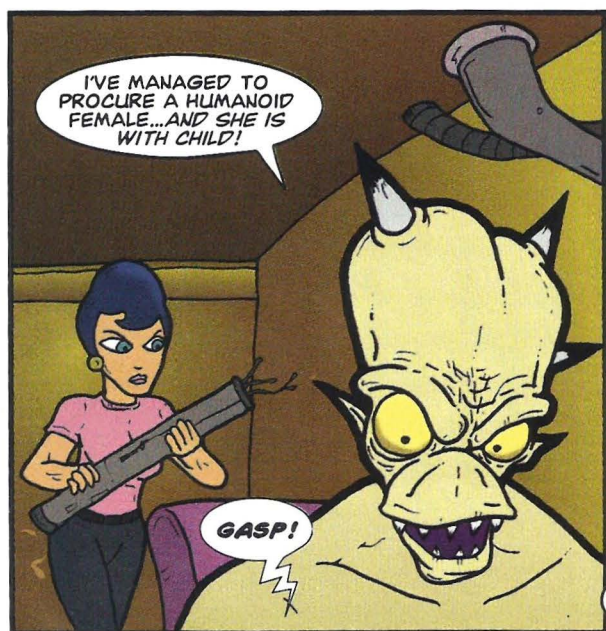

I'M EN ROUTE TO THE
MOTHERSHIP. THE UNBORN
FETUS IS HOUSED SAFELY INSIDE
ITS MOTHER'S UTERUS. I'LL NEED
YOU TO-



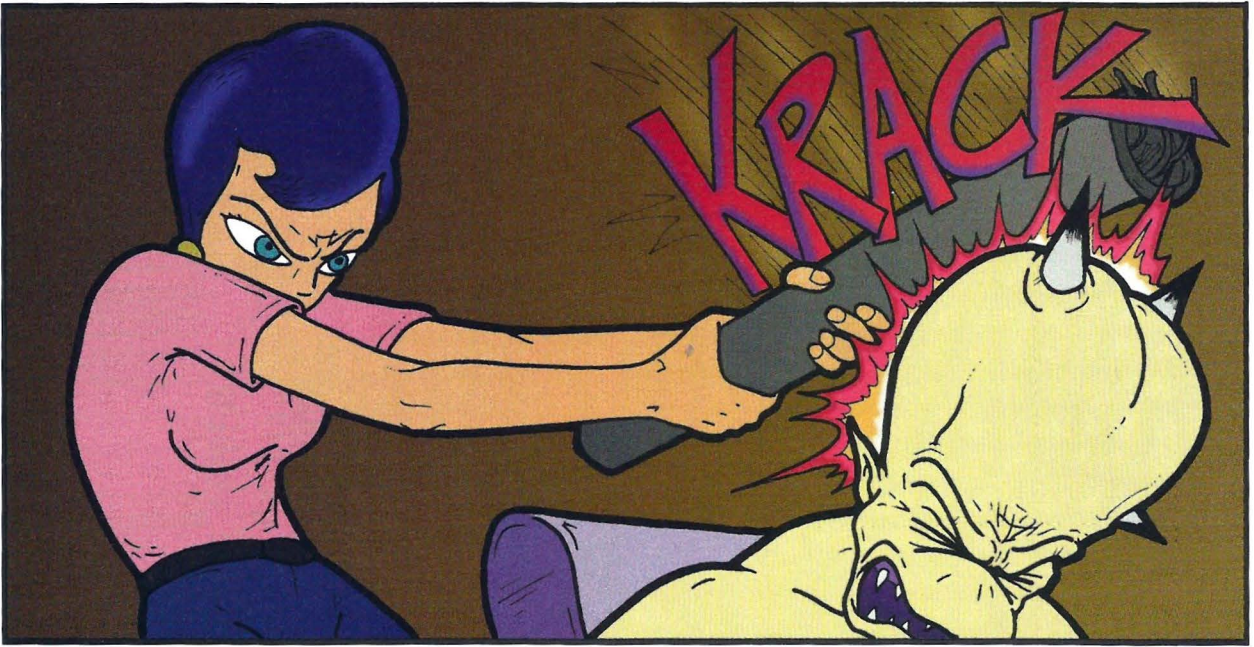



...AND THEN JIM'S HEAD TRANSFORMED INTO A GIANT WRECKING BALL...



...AND HE USED IT TO SMASH THE BEAST INTO JUICY BITS OF BONE AND FLESH!

WRECKING BALL, HUH?



WHERE'D YOU LEARN A TRICK LIKE THAT?

I DON'T KNOW.

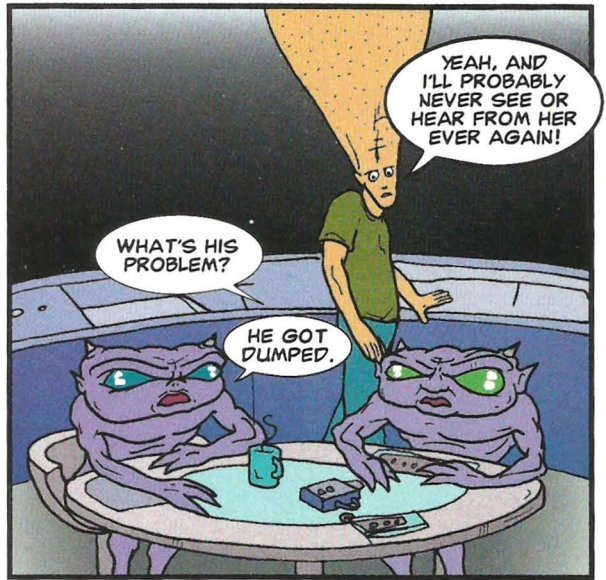

YEAH, AND I'LL PROBABLY NEVER SEE OR HEAR FROM HER EVER AGAIN!

WHAT'S HIS PROBLEM?

HE GOT DUMPED.

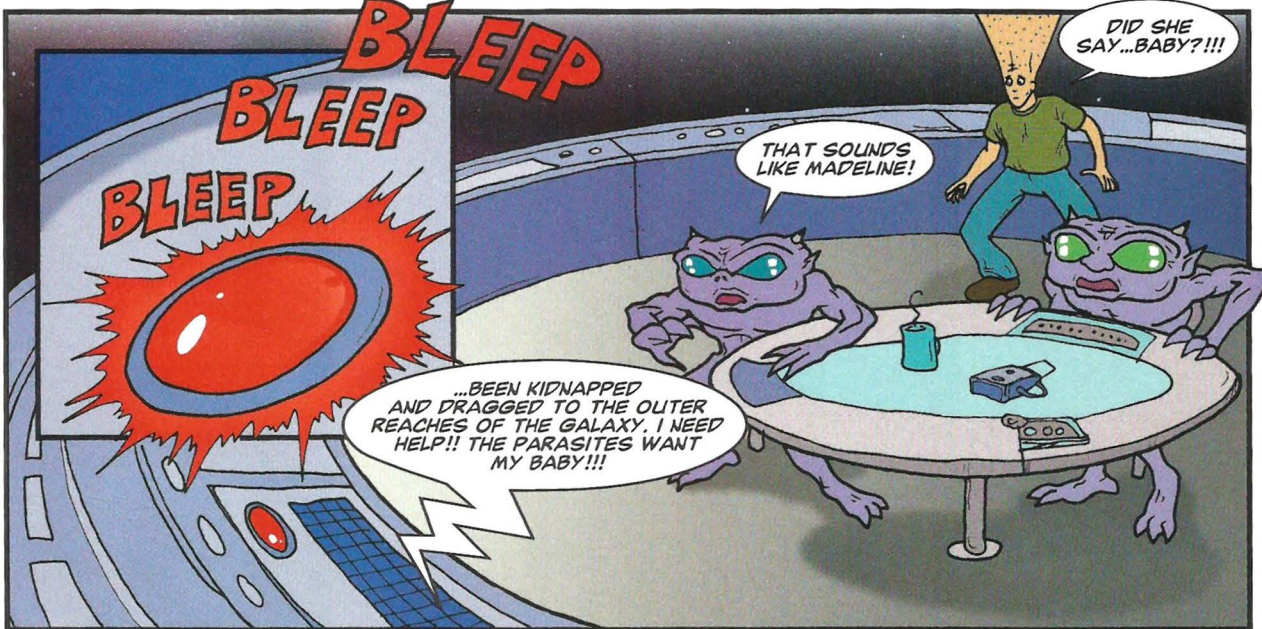

DID SHE SAY...BABY?!!!

THAT SOUNDS LIKE MADELINE!

...BEEN KIDNAPPED AND DRAGGED TO THE OUTER REACHES OF THE GALAXY. I NEED HELP!! THE PARASITES WANT MY BABY!!!





CHAPTER THREE

LIFE AND DEATH

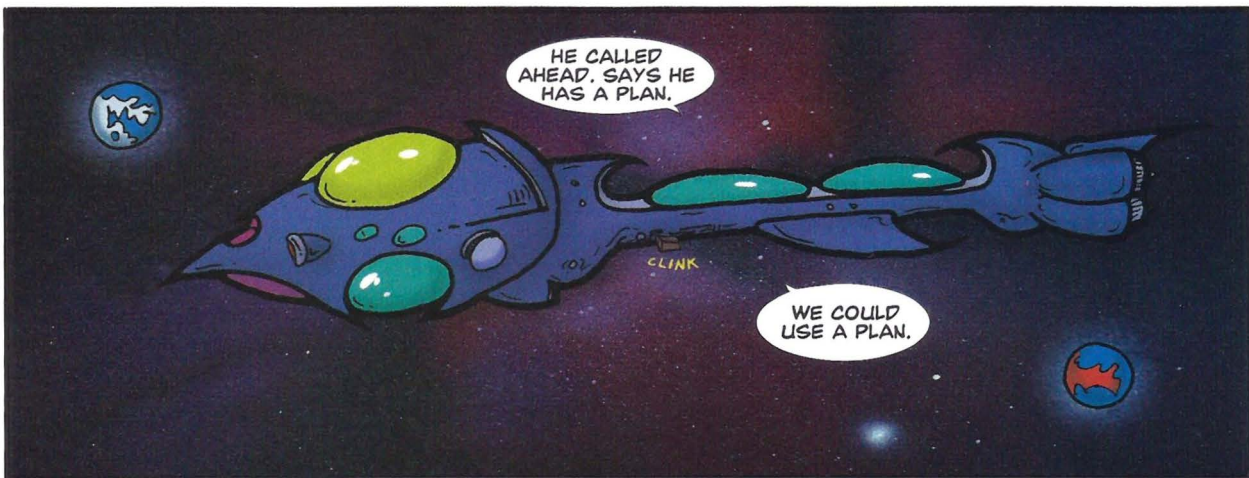



I'M SORRY WE WON'T BE SPENDING ANY QUALITY TIME TOGETHER, MY SWEET.

YOU MAKE ME NAUSEOUS.

AHHH, I WISH I COULD TAKE CREDIT...



...BUT I'M NOT THE ONE WHO KNOCKED YOU UP.



YOU'D BETTER HAVE A GOOD REASON FOR BEING HERE.



YOUR HIGHNESS, I HAVE THREE WORDS FOR YOU...



HUMANOID PRE-FAB HOUSING.

YOU BASTARD!

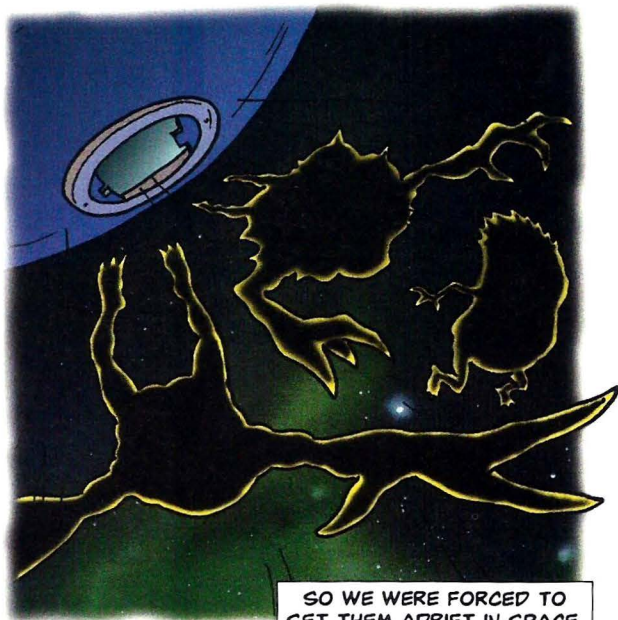
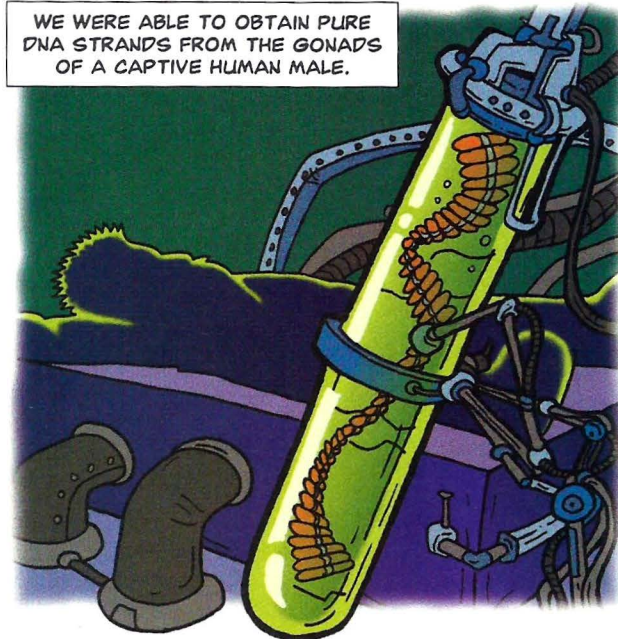
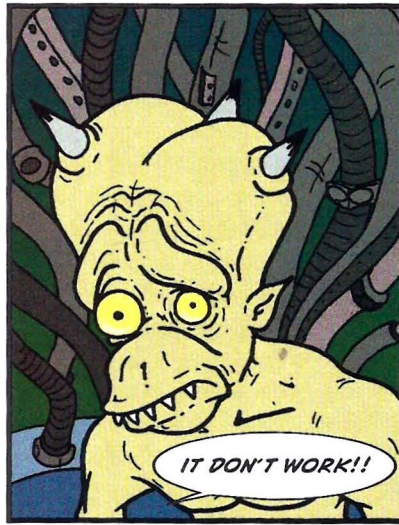

BUT THE RESULTS WERE MONSTEROUS, GENETIC MUTATIONS. UNCONTROLLABLE AND UNSUITED FOR PARASITIC HABITATION.

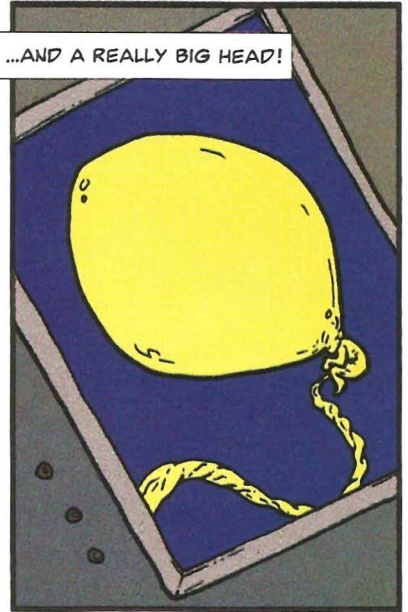
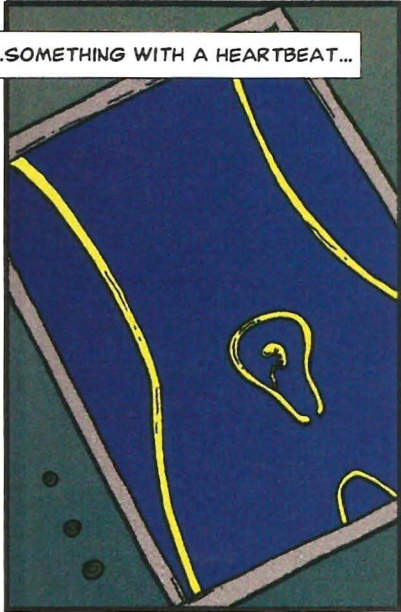

STAR MAP

-25'

BETA QUADRANT

OUR SOLAR SYSTEM

DELTA QUADRANT

MARK'S SPACE CRUISER

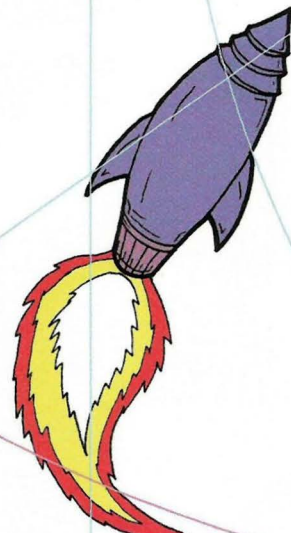
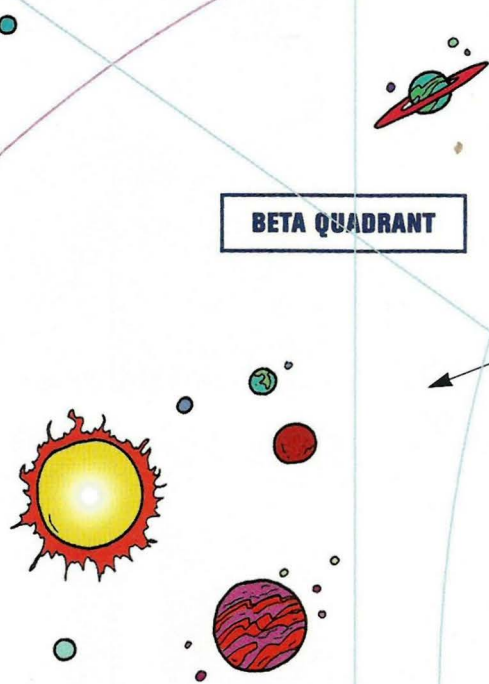

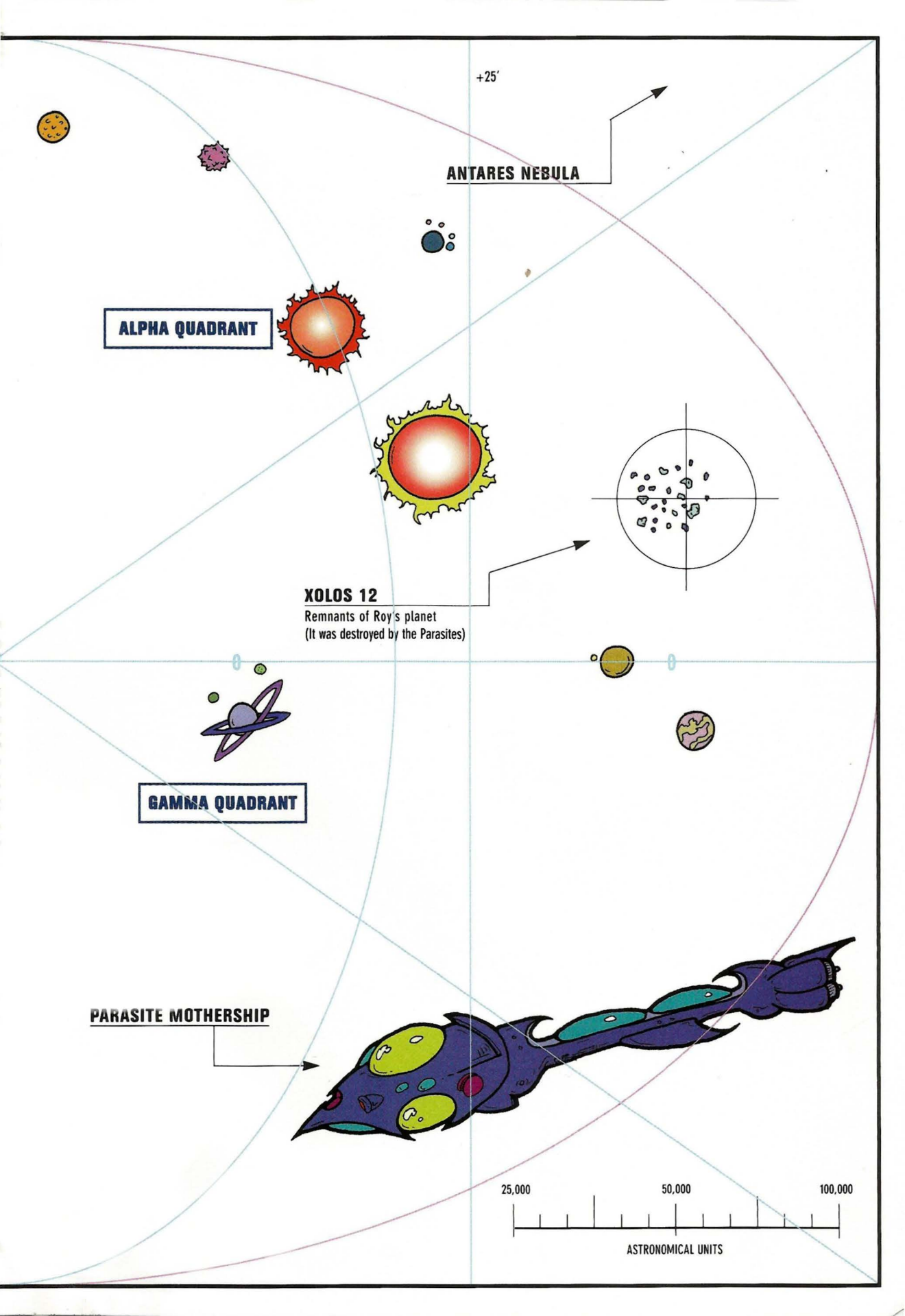

+25'

ANTARES NEBULA

ALPHA QUADRANT

XOLOS 12
Remnants of Roy's planet
(It was destroyed by the Parasites)

GAMMA QUADRANT

PARASITE MOTHERSHIP

25,000 50,000 100,000

ASTRONOMICAL UNITS

I'VE BEEN TRACKING MADELINE'S DISTRESS SIGNAL.

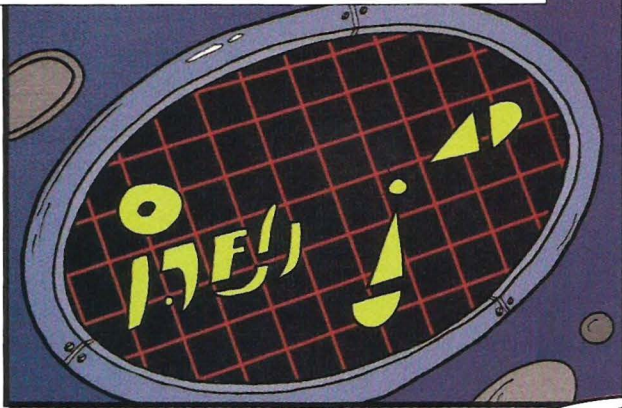

IT TERMINATES HERE...

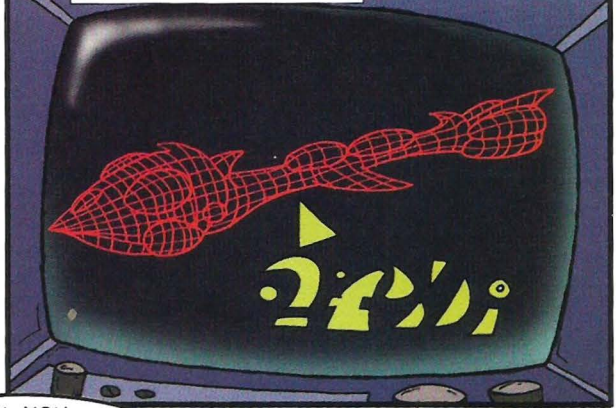

...AT THE MOTHERSHIP.



I CAN'T BELIEVE THIS! I THOUGHT THE PARASITES WERE DEFEATED. FINISHED.

JIM, YOU SHOULD KNOW BY NOW. NOTHING IS OVER 'TIL IT'S OVER.



WHAT WOULD THEY WANT WITH YOUR GIRLFRIEND?

WHATEVER IT IS, THEY CAN'T HAVE IT!

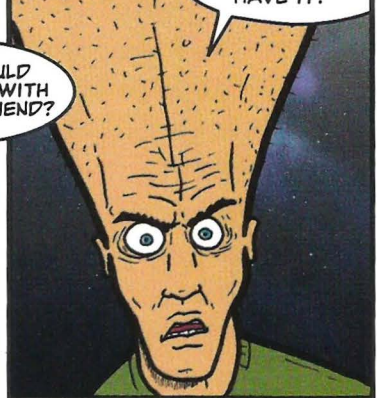

ARE YOU READY?

YEAH, I'M READY!

LET'S MOVE!



I COULD'VE SWORN SHE SAID SOMETHING ABOUT A BABY.

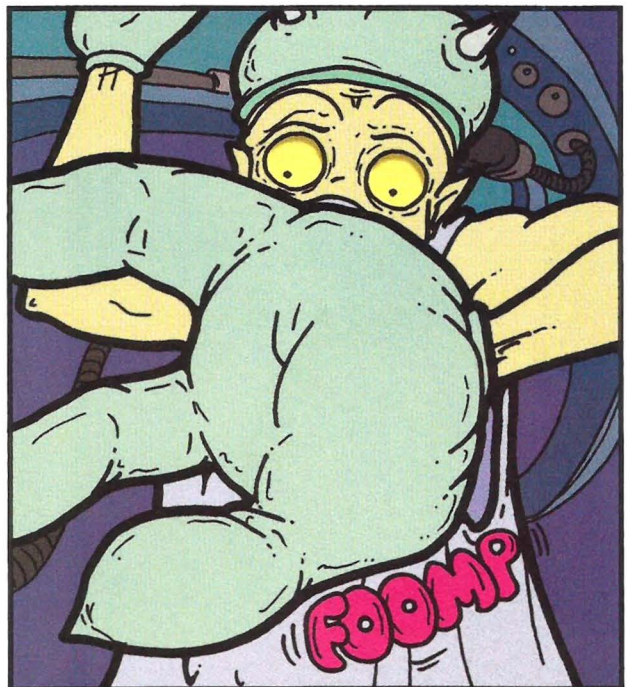
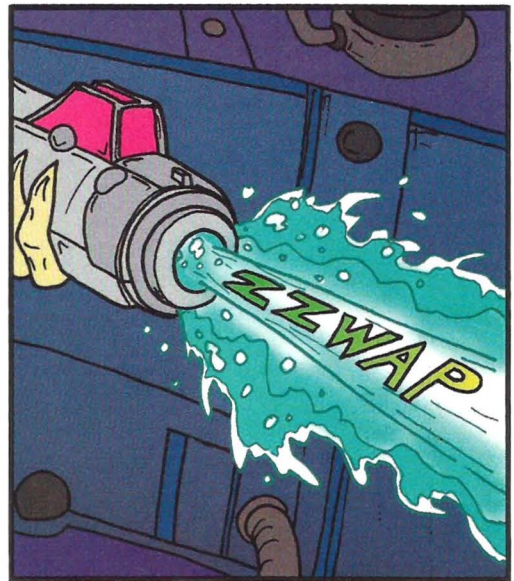
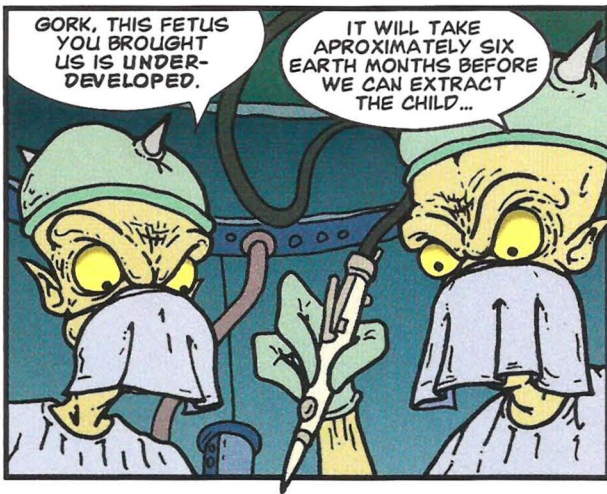



VERY EFFECTIVE.



CAN'T LET THEM TAKE MY BABY!

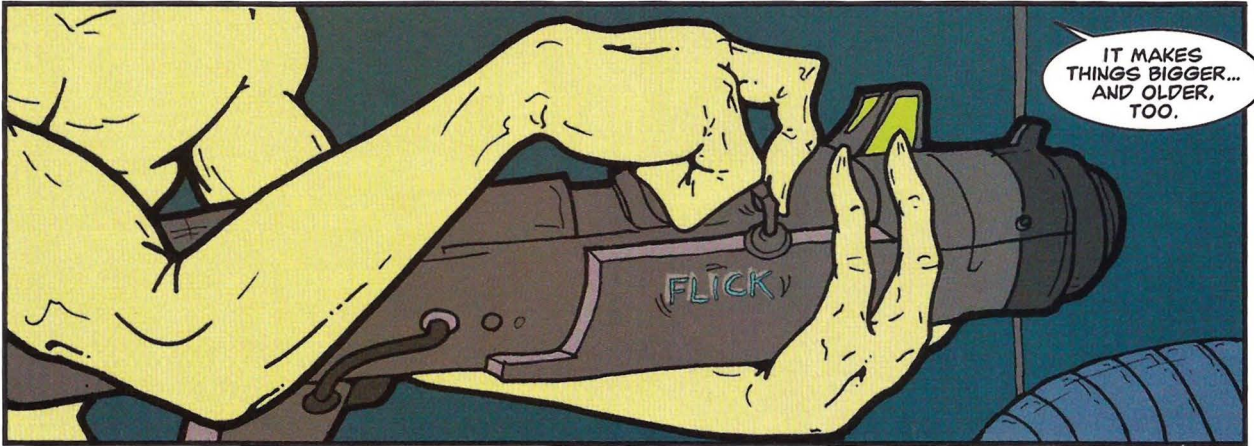

IT MAKES THINGS BIGGER... AND OLDER, TOO.



NNOOOO!

ZZWAP

PREPARE FOR EXTRACTION!

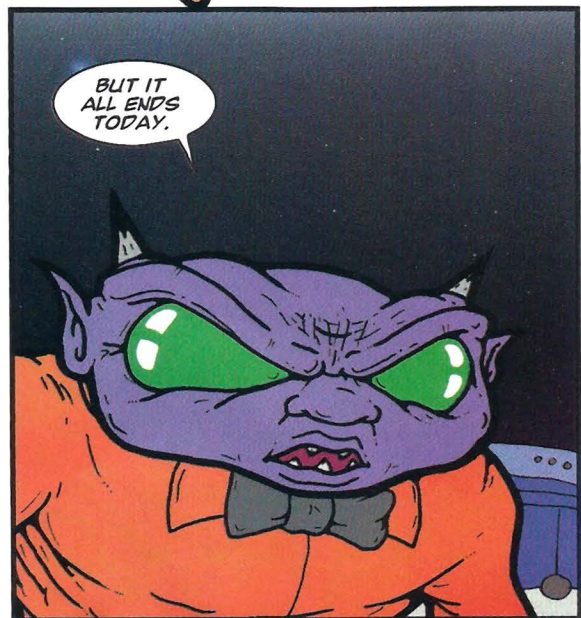
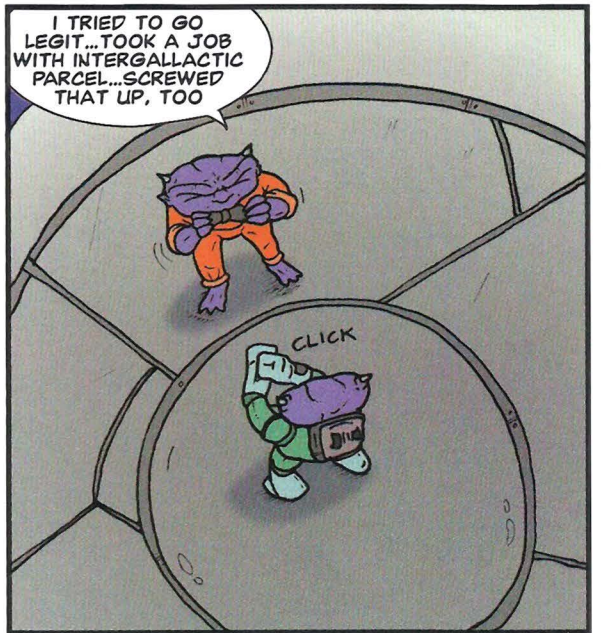
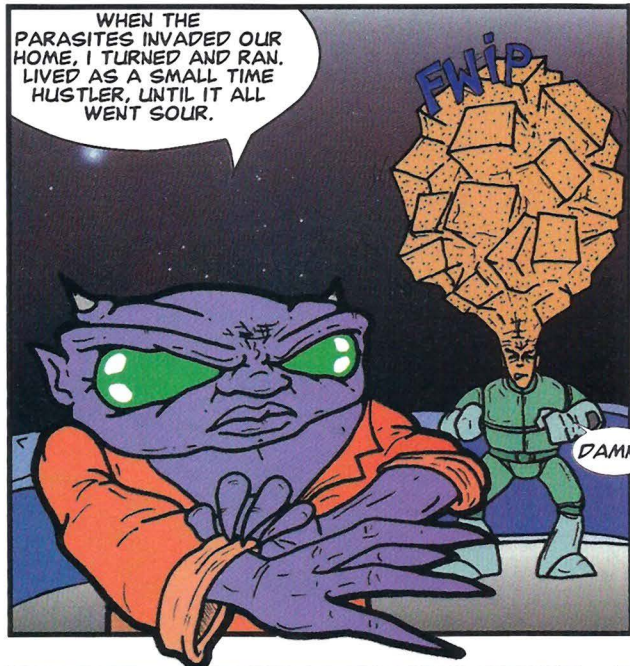
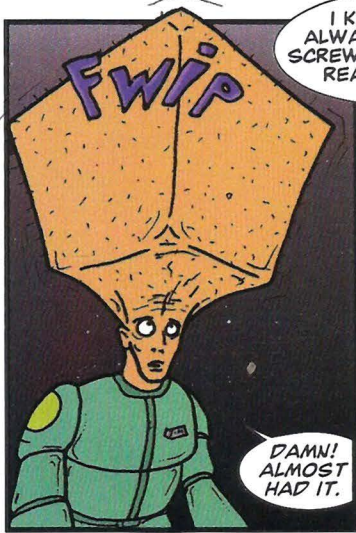

ADMINISTER THE SEDATIVE.

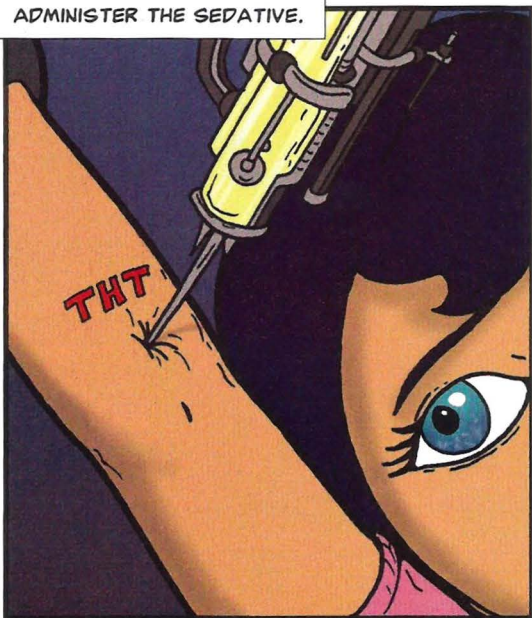

BRING DOWN THE OSCILLATOR PROBE.

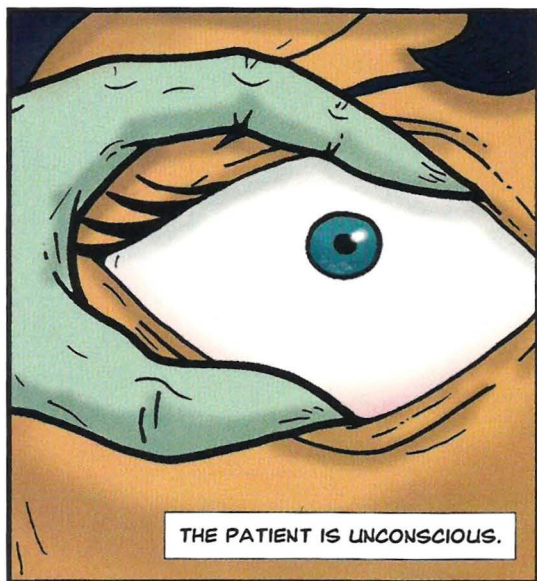
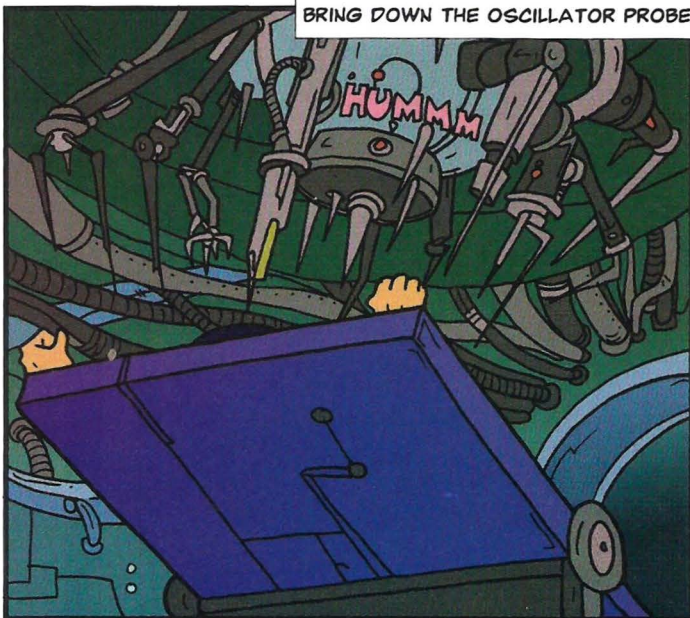

YOU MAY PROCEED.





GOT TO POOL ALL REMAINING STRENGTH...

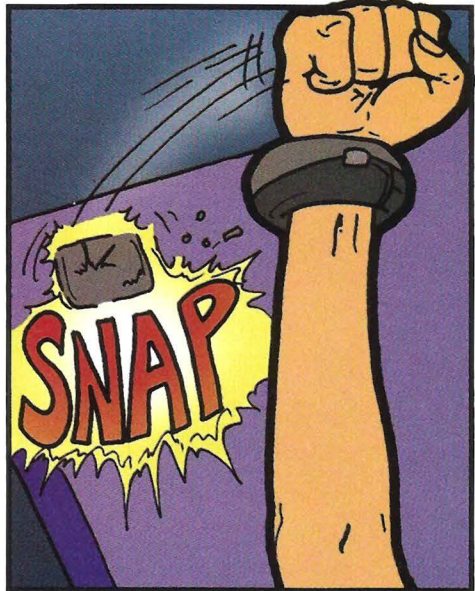

...AND MAKE ONE, LAST ATTEMPT...



...TO BREAK OUT OF HERE.

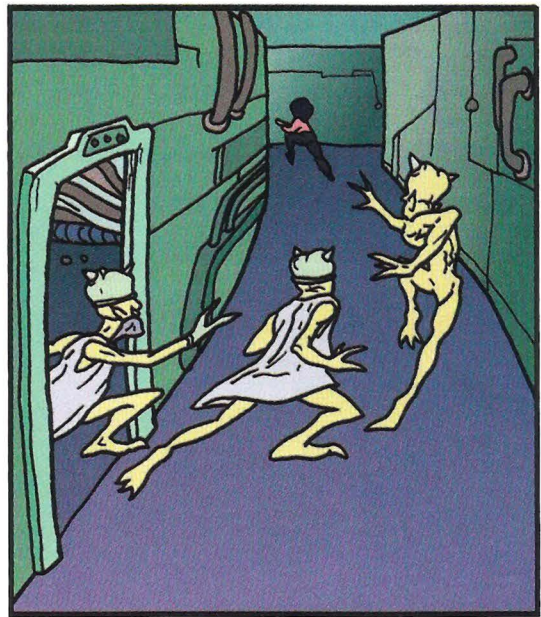

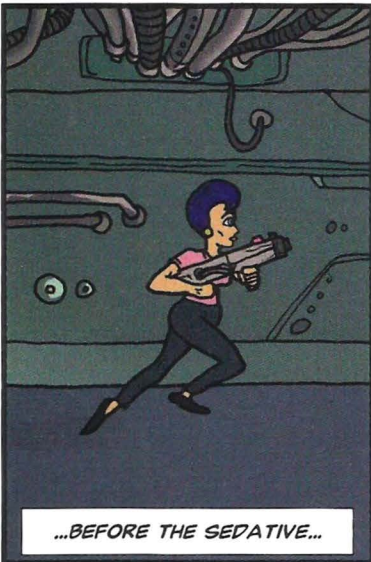
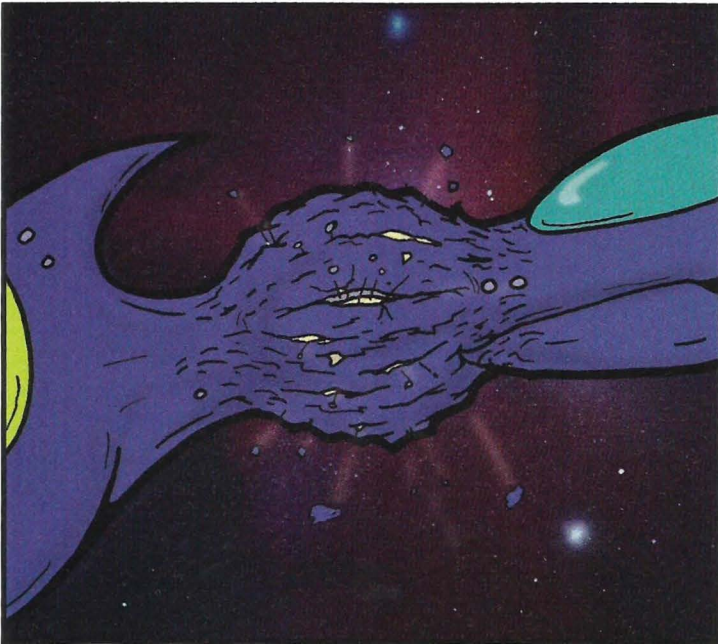
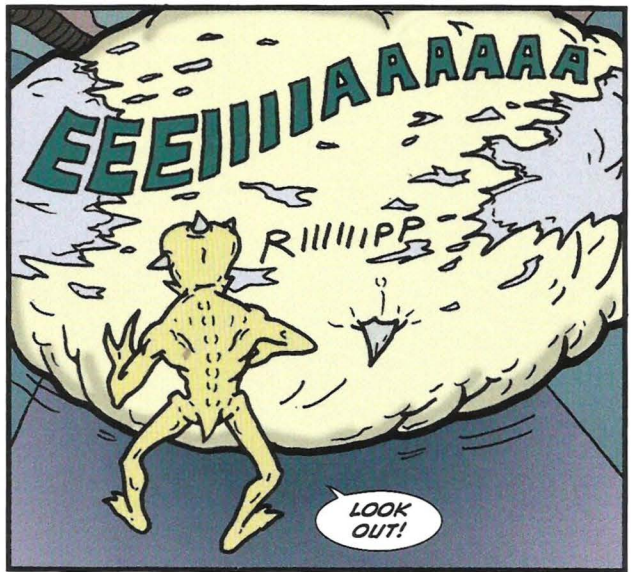
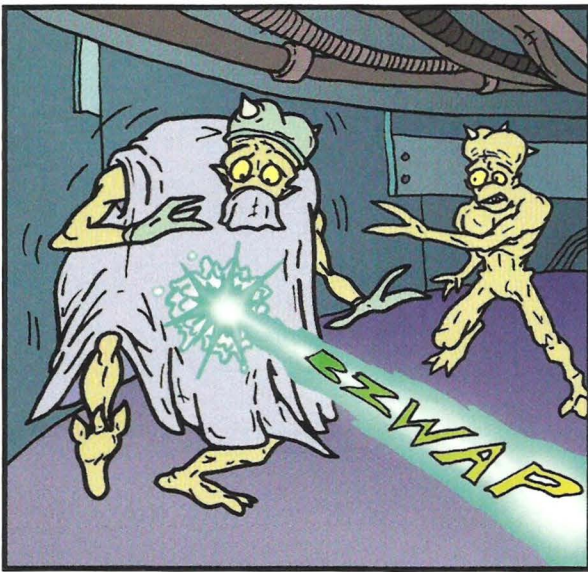

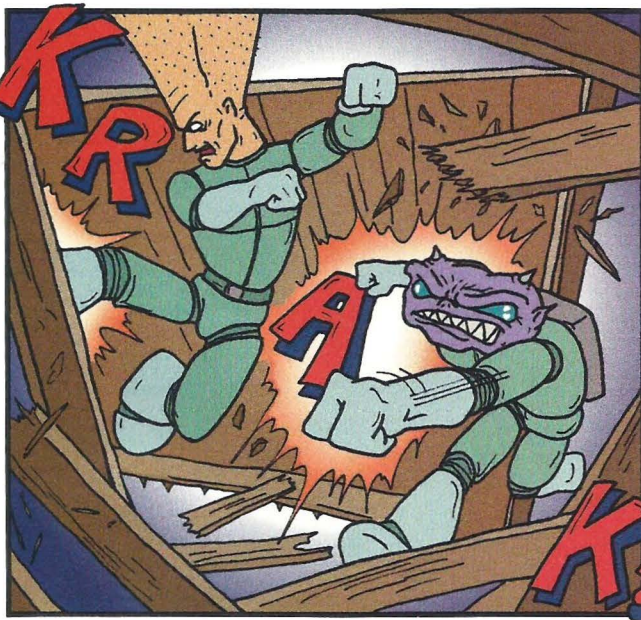
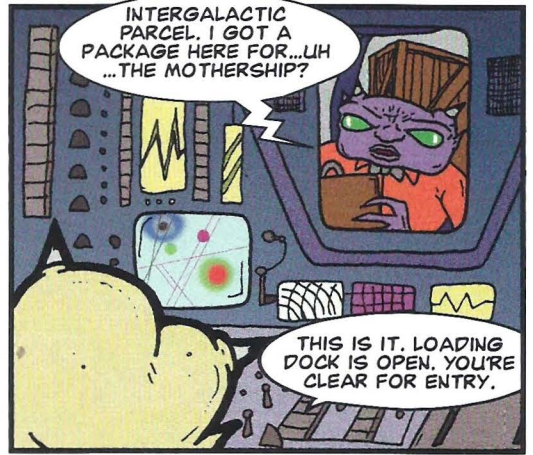
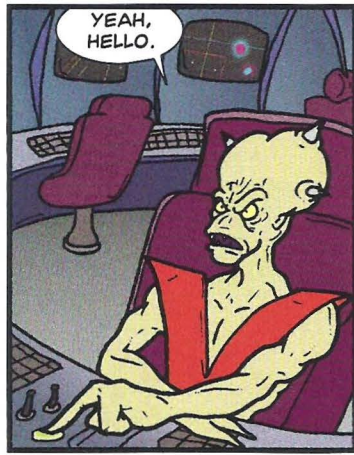
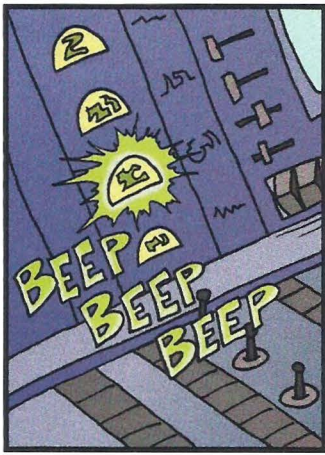

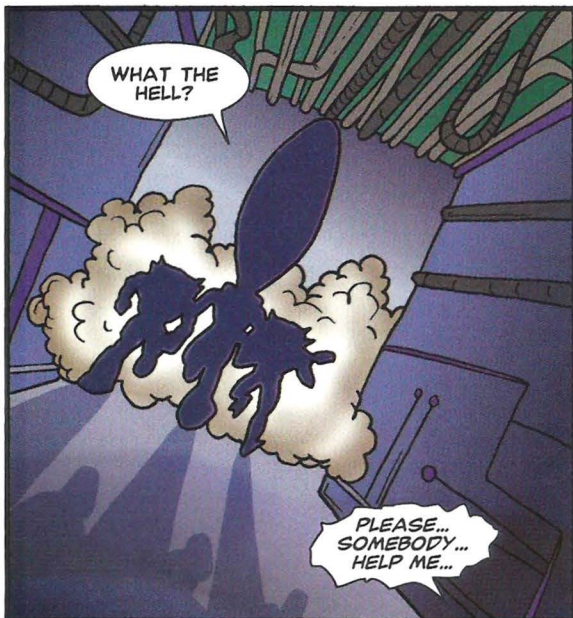
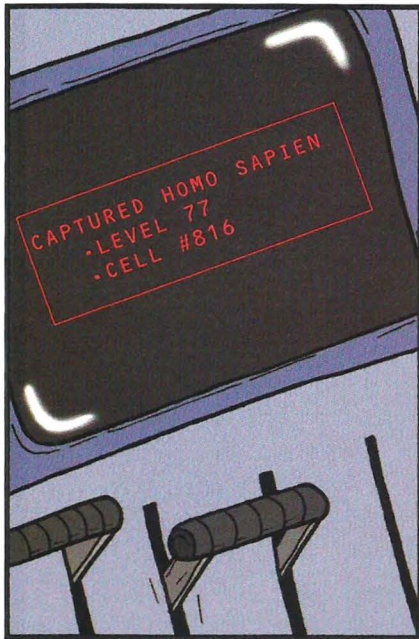
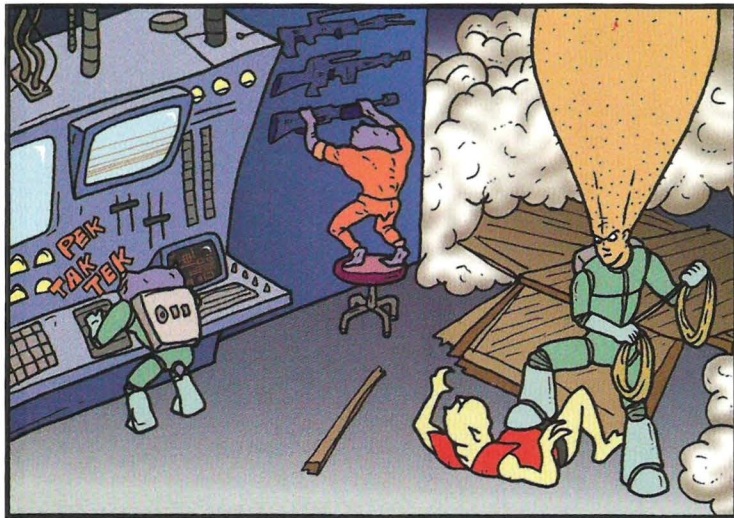



IT IS NO SECRET TO ME THAT MANY OF YOU HAVE BECOME UNHAPPY WITH MY LEADERSHIP.



THE INVASION OF EARTH WAS A FAILURE FROM WHICH WE HAVE NOT BEGUN TO RECOVER. AS YOUR KING, IT IS MY DUTY TO SHOULDER THE BURDEN OF OUR MISERY AND LEAD US BRAVELY INTO THE FUTURE.

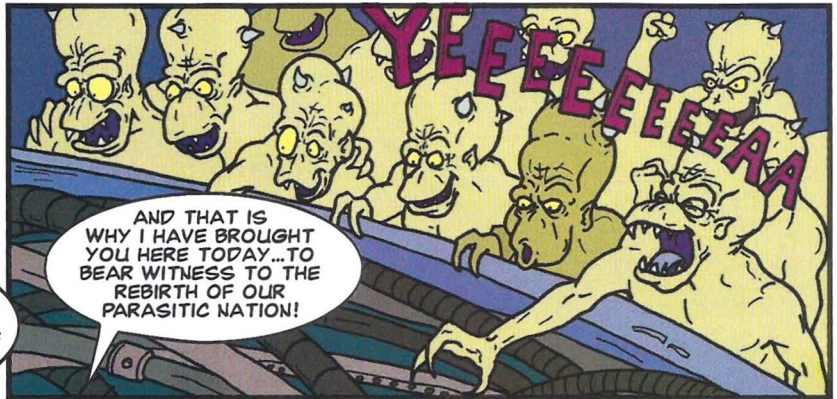
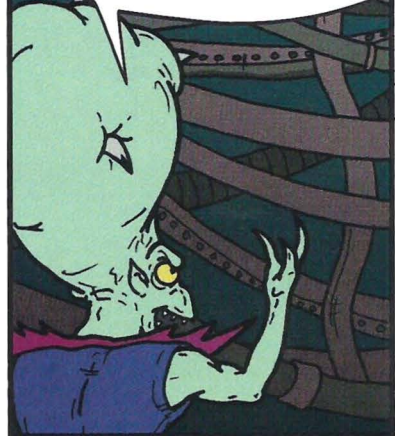

AND THAT IS WHY I HAVE BROUGHT YOU HERE TODAY...TO BEAR WITNESS TO THE REBIRTH OF OUR PARASITIC NATION!



HISTORICALLY, WE HAVE BEEN CONQUERORS - INVADING, DECIMATING, AND MOVING ON.

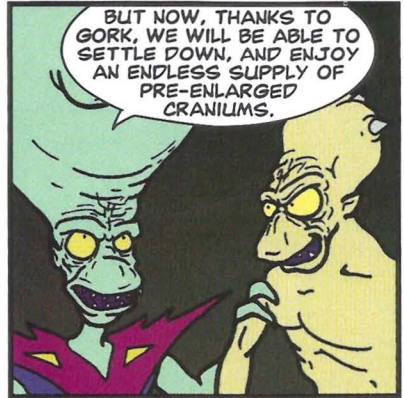

BUT NOW, THANKS TO GORK, WE WILL BE ABLE TO SETTLE DOWN, AND ENJOY AN ENDLESS SUPPLY OF PRE-ENLARGED CRANIUMS.



WE WILL REMOVE THE INFANT FROM THIS EARTH WOMAN AND PRODUCE MILLIONS OF READY-TO-INHABIT CLONES.



THEN, FOR YOUR ENTERTAINMENT, I WILL KILL THE MOTHER... VERY SLOWLY!



FIRE IN THE HOLE!!

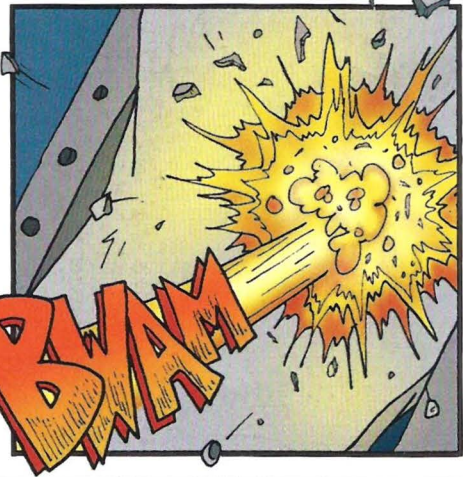

BAM



MADLINE!!!

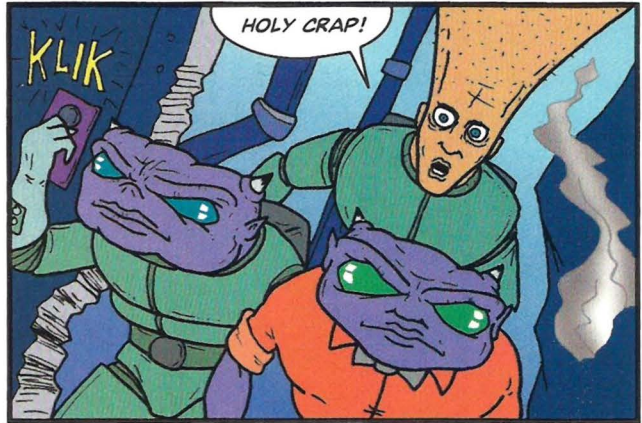

HOLY CRAP!

KLIK

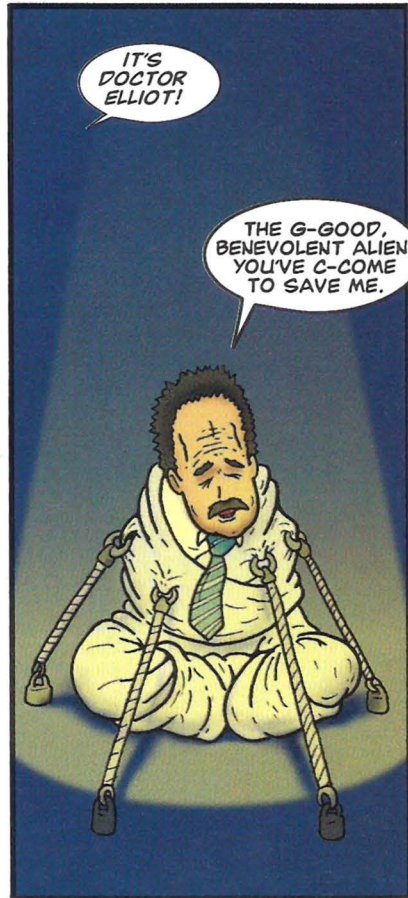

IT'S DOCTOR ELLIOT!

THE G-GOOD, BENEVOLENT ALIEN. YOU'VE C-COME TO SAVE ME.



NOT REALLY.



BUT YOU MUST! T-THESE ARE THE BAD ALIENS. I UNDERSTAND NOW. THEY LIKE TO HURT ME. I-I WANT TO GO HOME!!!



TRY TO CALM DOWN. WE'VE GOT A FLYING SAUCER PARKED IN THE LOADING DOCK, AND YOU CAN-



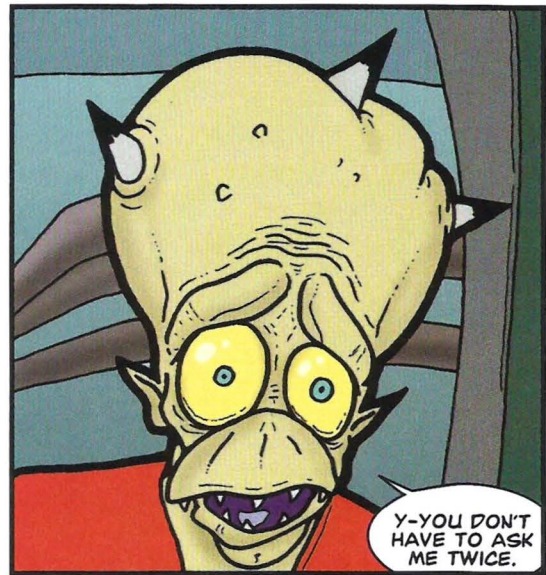

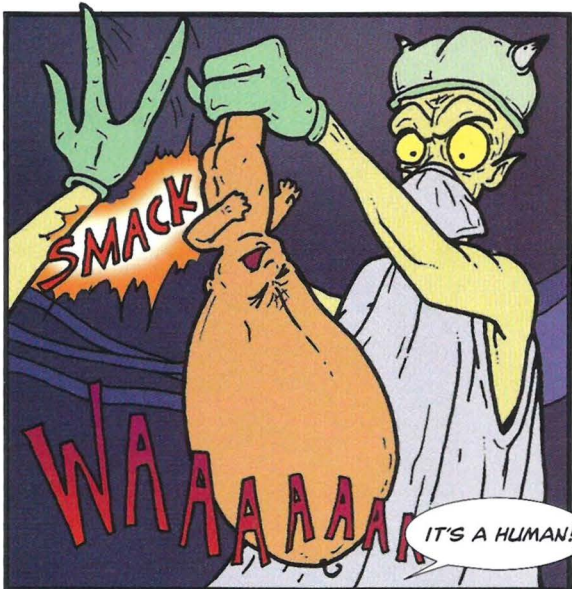

THE PARASITES
WILL RULE THE
GALAXY ONCE
AGAIN!

GORK IS RIGHT!
NOTHING CAN
STOP US!

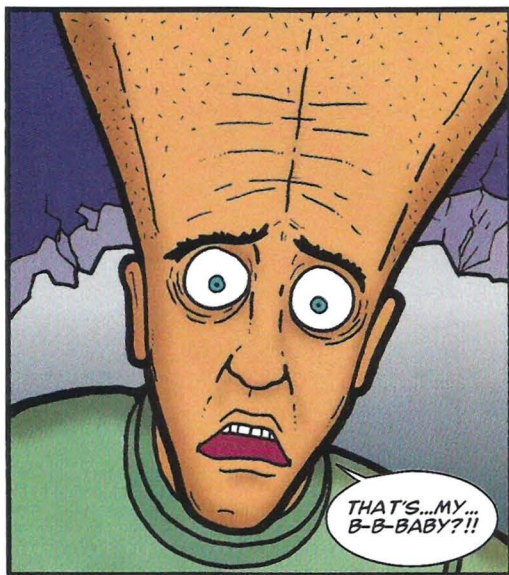
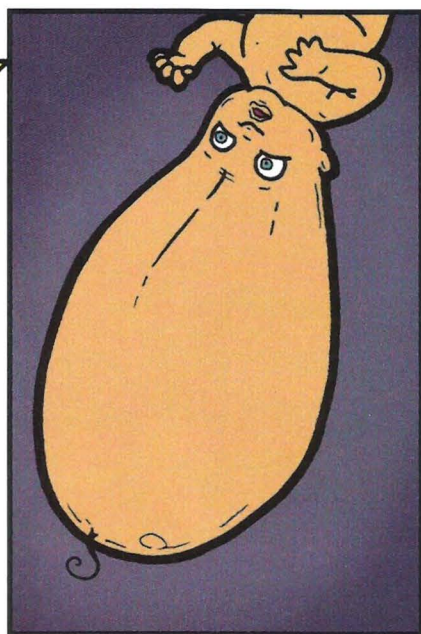
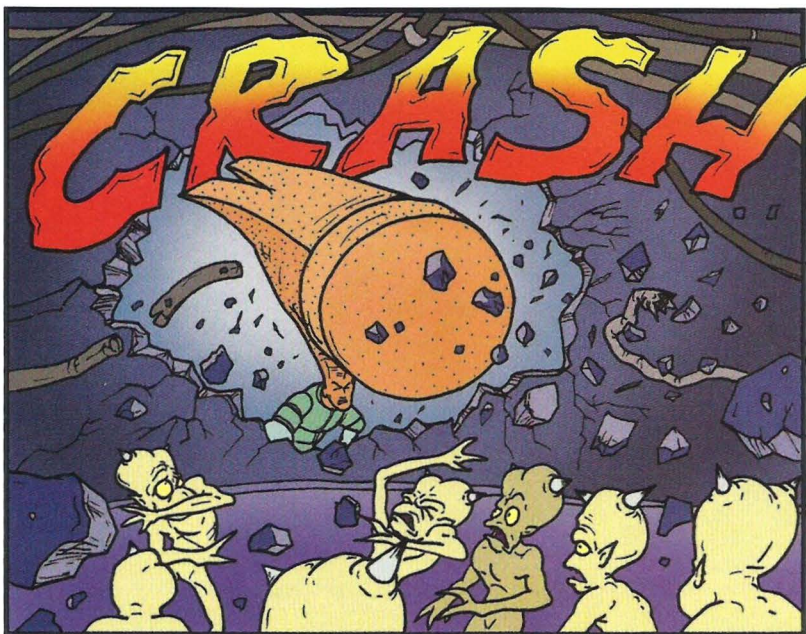
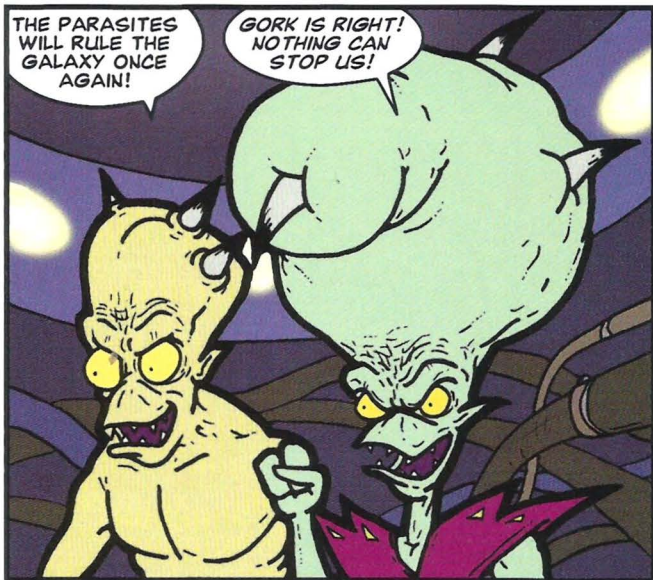

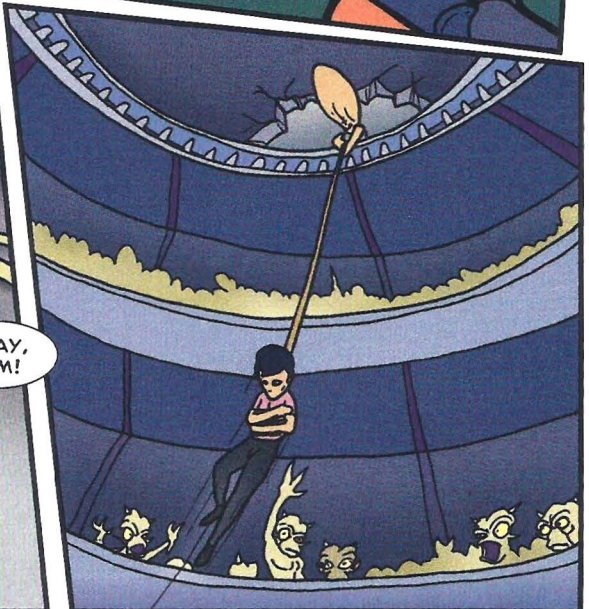
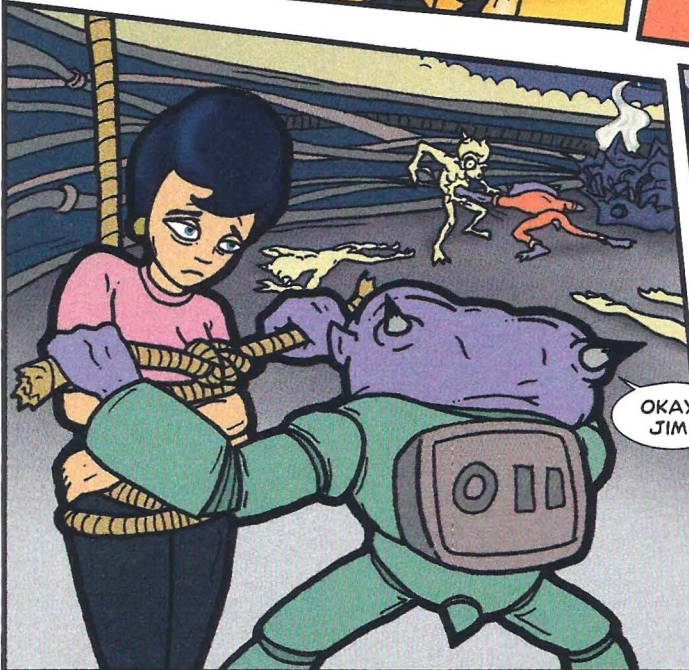
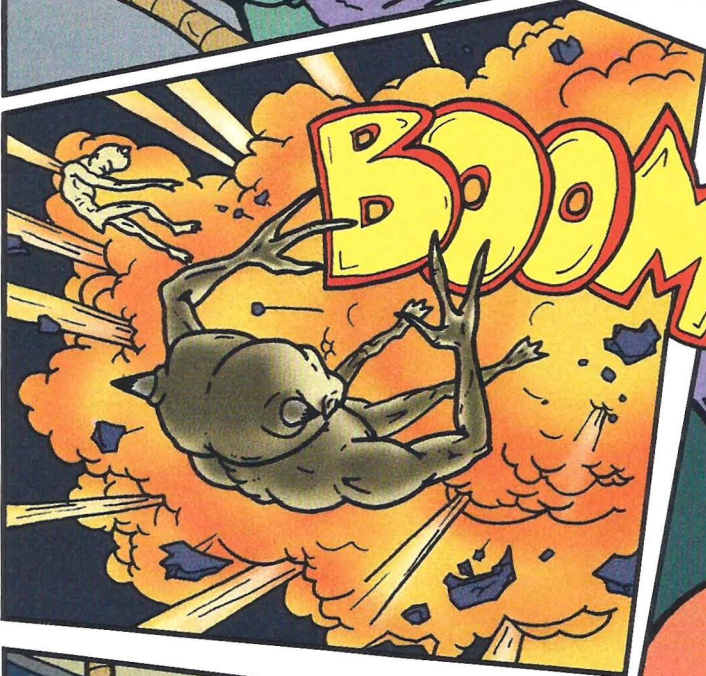
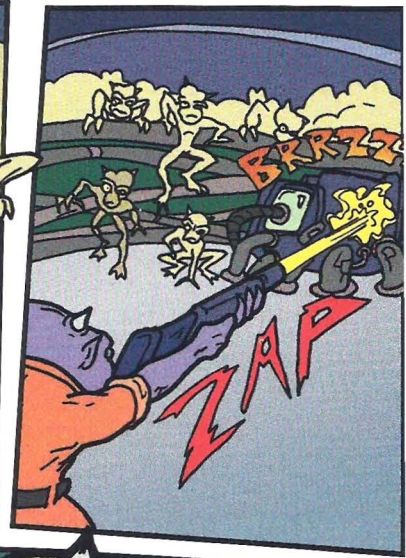



"DON'T TOUCH ANYTHING," THEY SAID. "JUST WAIT FOR US IN THE FLYING SAUCER." THEY TOLD ME...BUT THEY REFUSED TO LISTEN.

AWAY FROM EARTH NOW, FOR SO MANY MONTHS.



HOW AM I REMEMBERED BACK HOME...IF AT ALL?



ONE'S OFFSPRING ARE HIS ONLY LASTING LEGACY. AND MY OWN...TORN FROM MY BODY BY THESE ALIEN BEASTS, THEN SCATTERED IN SPACE LIKE SO MUCH DISPOSABLE GARBAGE.

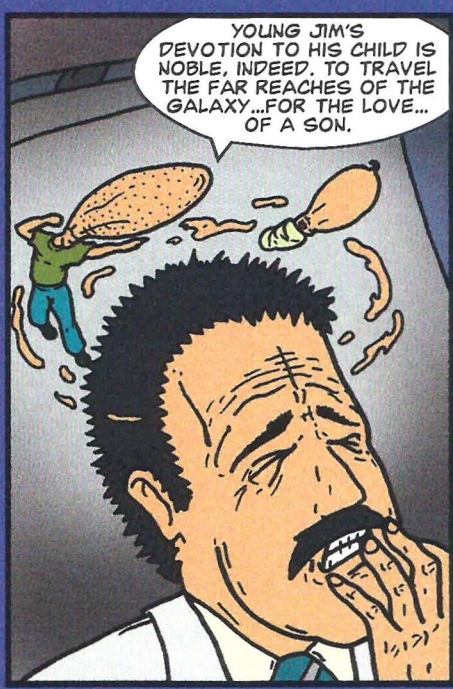

YOUNG JIM'S DEVOTION TO HIS CHILD IS NOBLE, INDEED. TO TRAVEL THE FAR REACHES OF THE GALAXY...FOR THE LOVE... OF A SON.

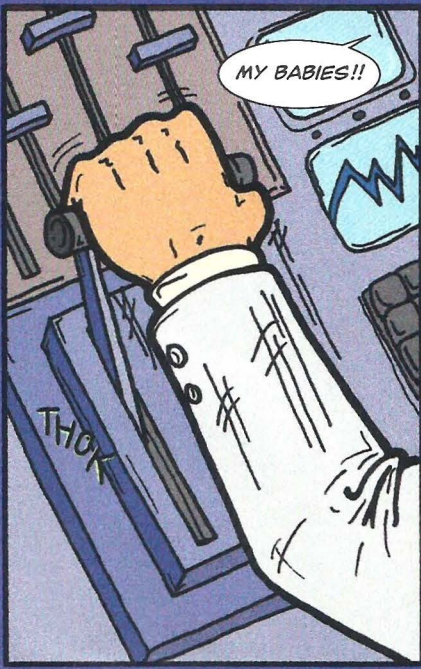

MY BABIES!!

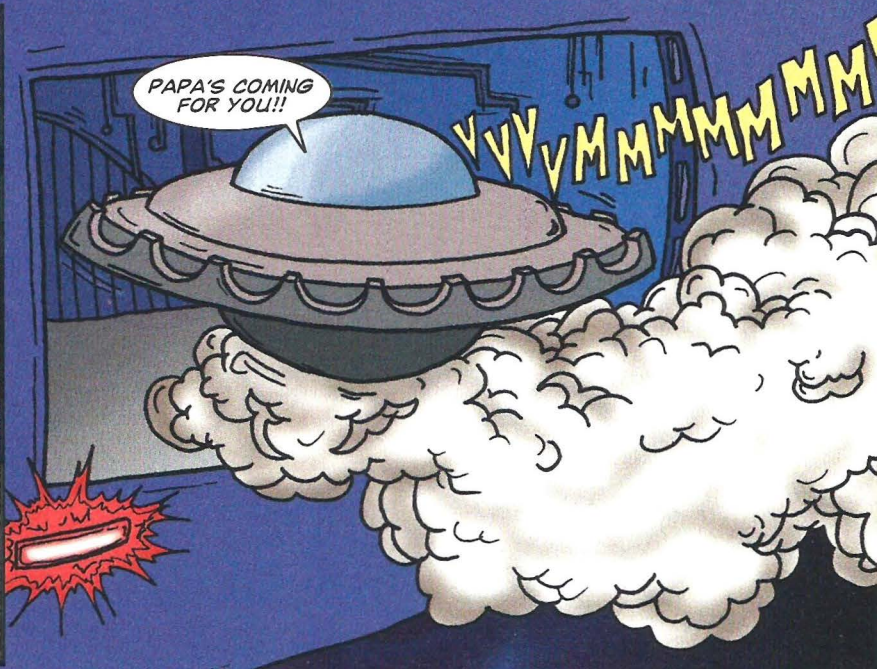

PAPA'S COMING FOR YOU!!

VVV VMMMMMMMM

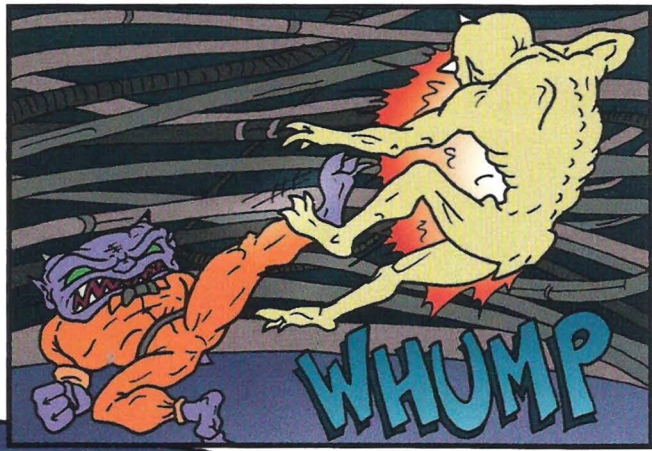

JIM...WHAT...
ARE YOU...?

NEVER MIND. CAN
YOU WALK?

RUN!!!





THEY'RE GAINING!



HEY, ISN'T THAT OUR RIDE?

ELLIOT! FRIGGIN' NUT JOB!!



NOW WHAT?

PLEASE... HELP... ME... PLEASE...



JIM, CAN YOU STILL DO THAT THING WITH YOUR HEAD?

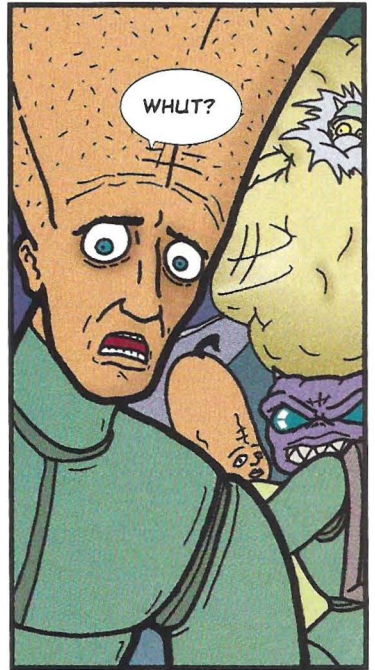

WHUT?



BWA-WHOOM!



My Shrimp Specialty
by Jim

need: 1 lb. Shrimp
1 bulb of Garlic
Olive Oil
Linguine

directions: 1. Peel & de-vein Shrimp. SAVE THE SHELLS
2. Boil the shells in salted water until you get a tasty opaque-ish broth. Strain & set aside

The Big Secret →

3. Smash & chop up the garlic. (use a knife if time permits)

4. Heat some oil in a skillet.

Add the garlic. Stir.

Add the Shrimp. Stir.

Add the shrimp Juice. Cover & cook.

Serve over linguine for a romantic dinner!

Don't overcook the Shrimp!!





CHAPTER FOUR

INFANTILE BEHAVIOR

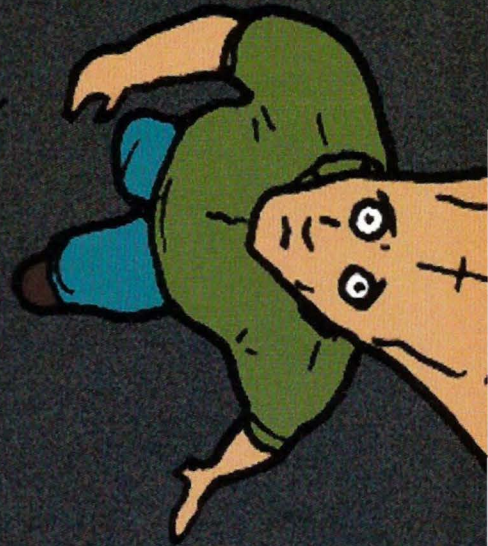

IT IS COLD IN SPACE.

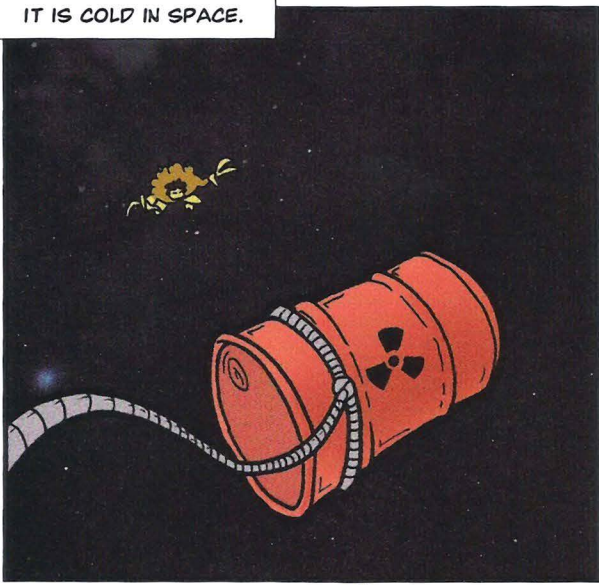

VERY DARK...AND OHHHHHH SO VERY COLD.

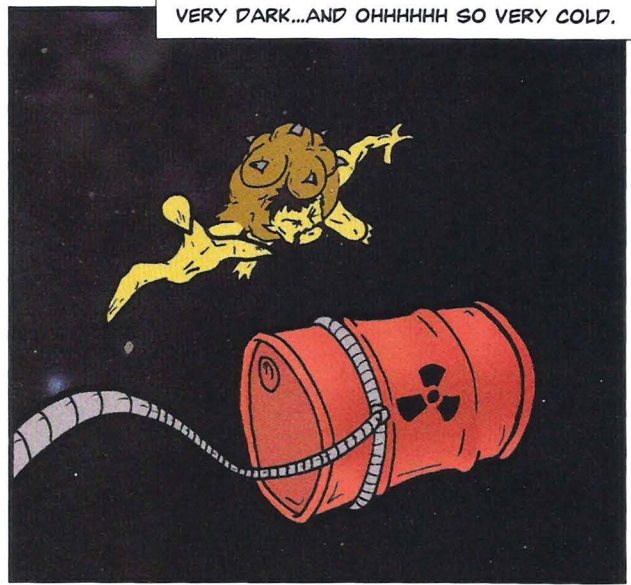

BUT WARMTH, TOO,
CAN BE FOUND.

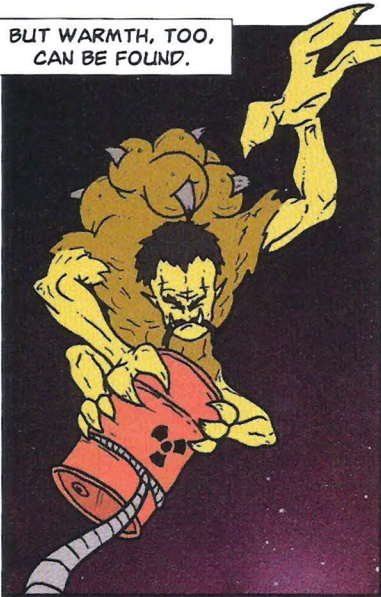

DANGLING, ON A LINE,
AT THE END OF A FATHER'S
OUTSTRETCHED HAND.



LIKE A SUCKLING PIGLET
AT ITS MOTHER'S TEAT...



...DRINK NOW AND GROW
STRONG MY SON...

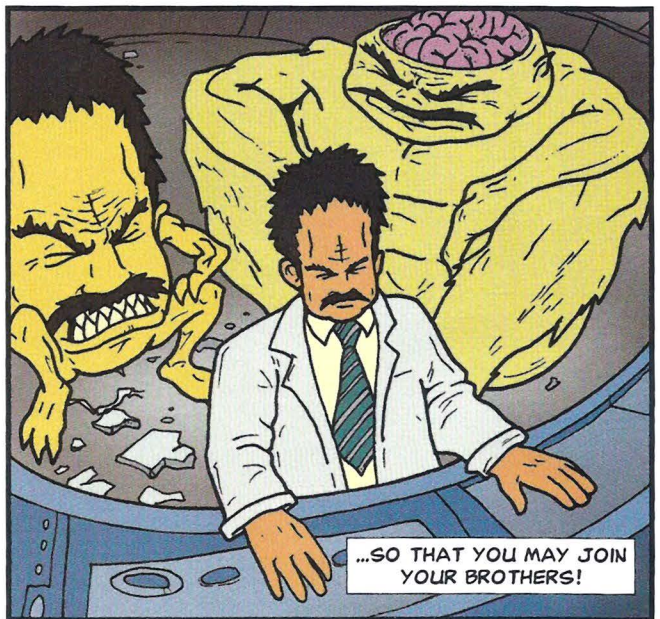
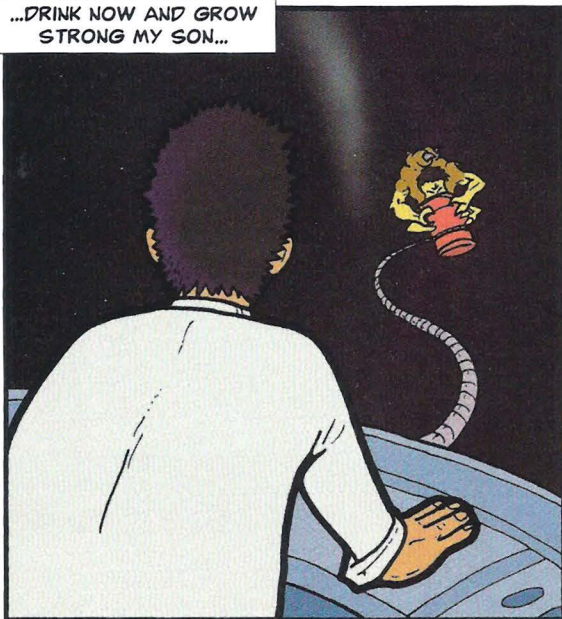

...SO THAT YOU MAY JOIN
YOUR BROTHERS!

MARK MADE THE ULTIMATE SACRIFICE. SAVING OUR LIVES...
AND DESTROYING THE PARASITES ONCE AND FOR ALL.

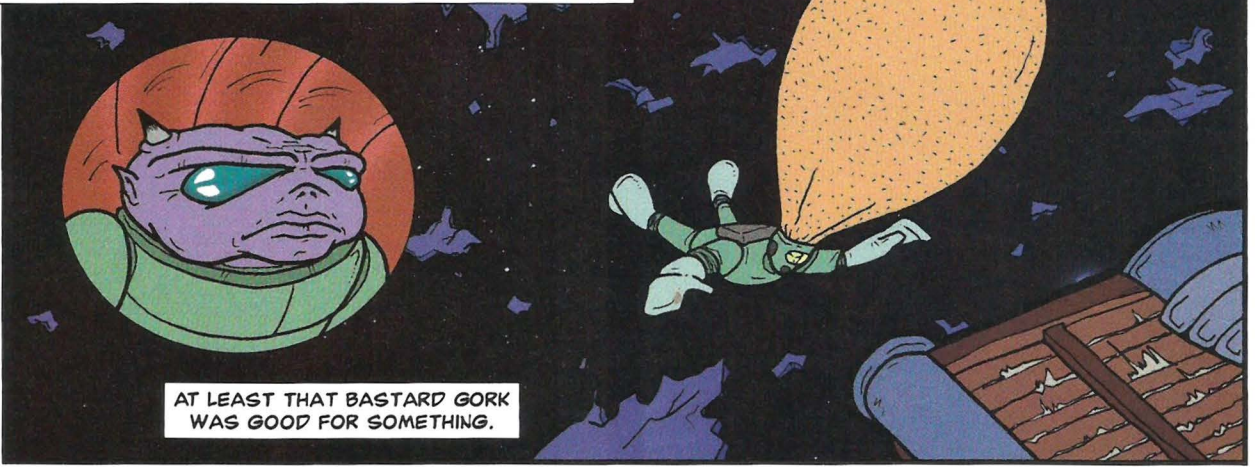

AT LEAST THAT BASTARD GORK
WAS GOOD FOR SOMETHING.

WE WERE ABLE TO CLIMB ABOARD
HIS HOME-MADE SPACE SHIP.

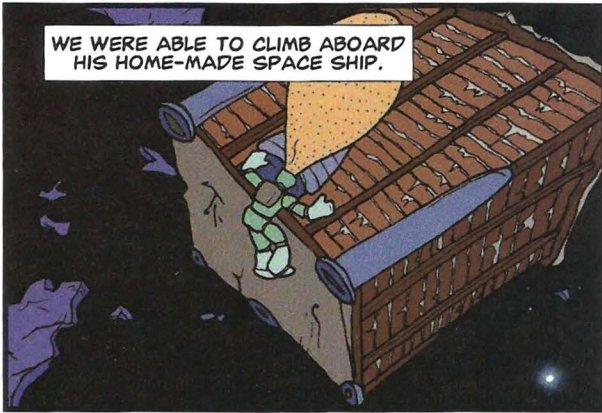

FORTUNATELY, THE TRANS-WARP
ENGINES SURVIVED THE BLAST.

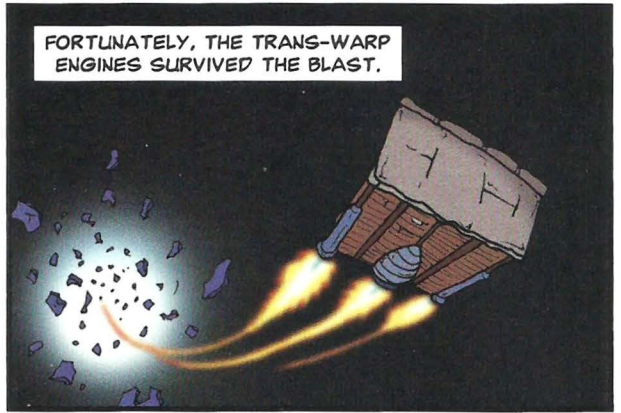

I STILL MISS MARK, THOUGH.



HE'S THE MOST
BEAUTIFUL THING
I'VE EVER SEEN.

YEAH.

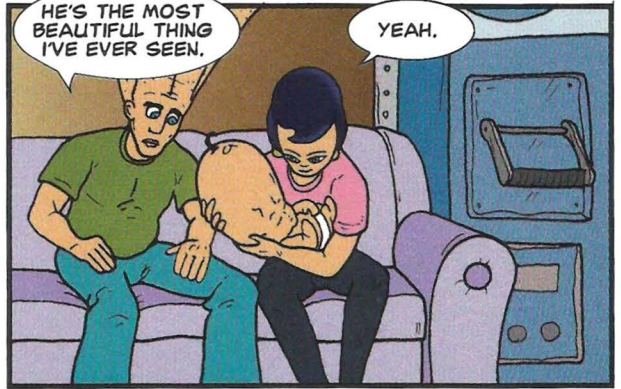

I-I KNOW I'VE BEEN A
BIG JERK...BUT I'M
GONNA CHANGE.

I NEVER
WANTED TO
CHANGE
YOU.



JUST MAKE YOU
SEE THE IMPORTANT
THINGS.



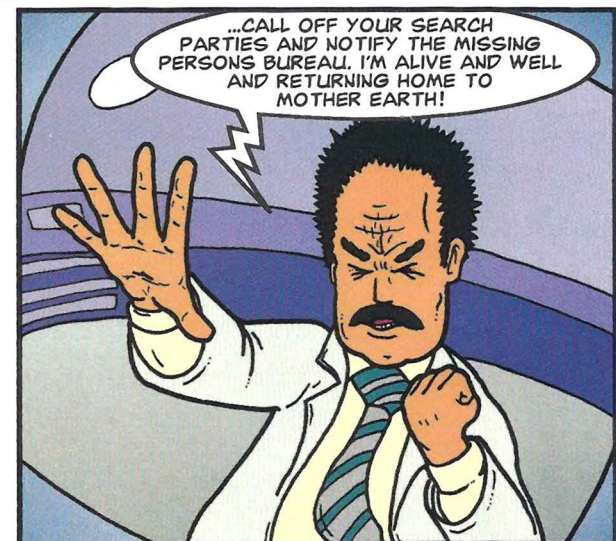
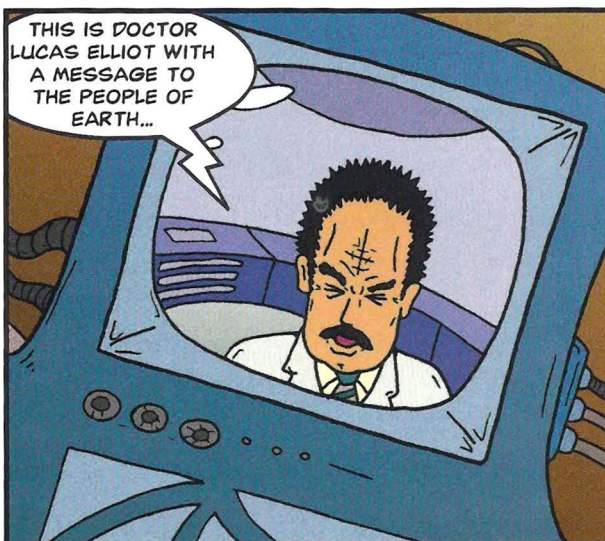
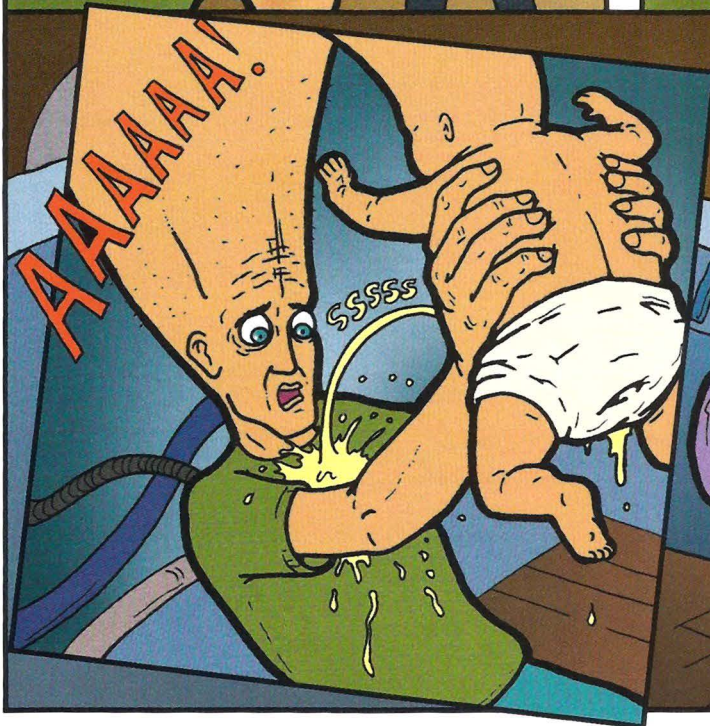

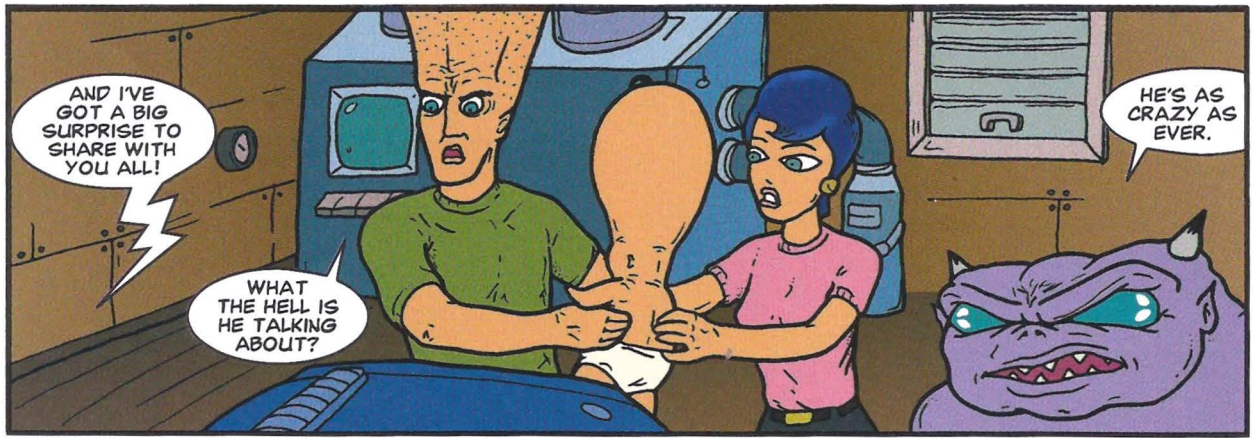

AND I'VE GOT A BIG SURPRISE TO SHARE WITH YOU ALL!

HE'S AS CRAZY AS EVER.

WHAT THE HELL IS HE TALKING ABOUT?

PREPARE FOR RE-ENTRY.

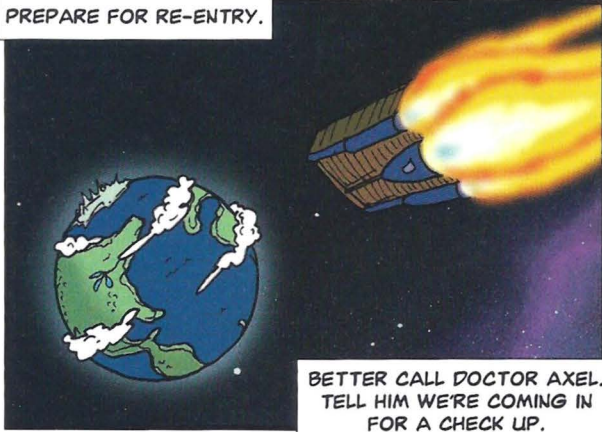

BETTER CALL DOCTOR AXEL. TELL HIM WE'RE COMING IN FOR A CHECK UP.

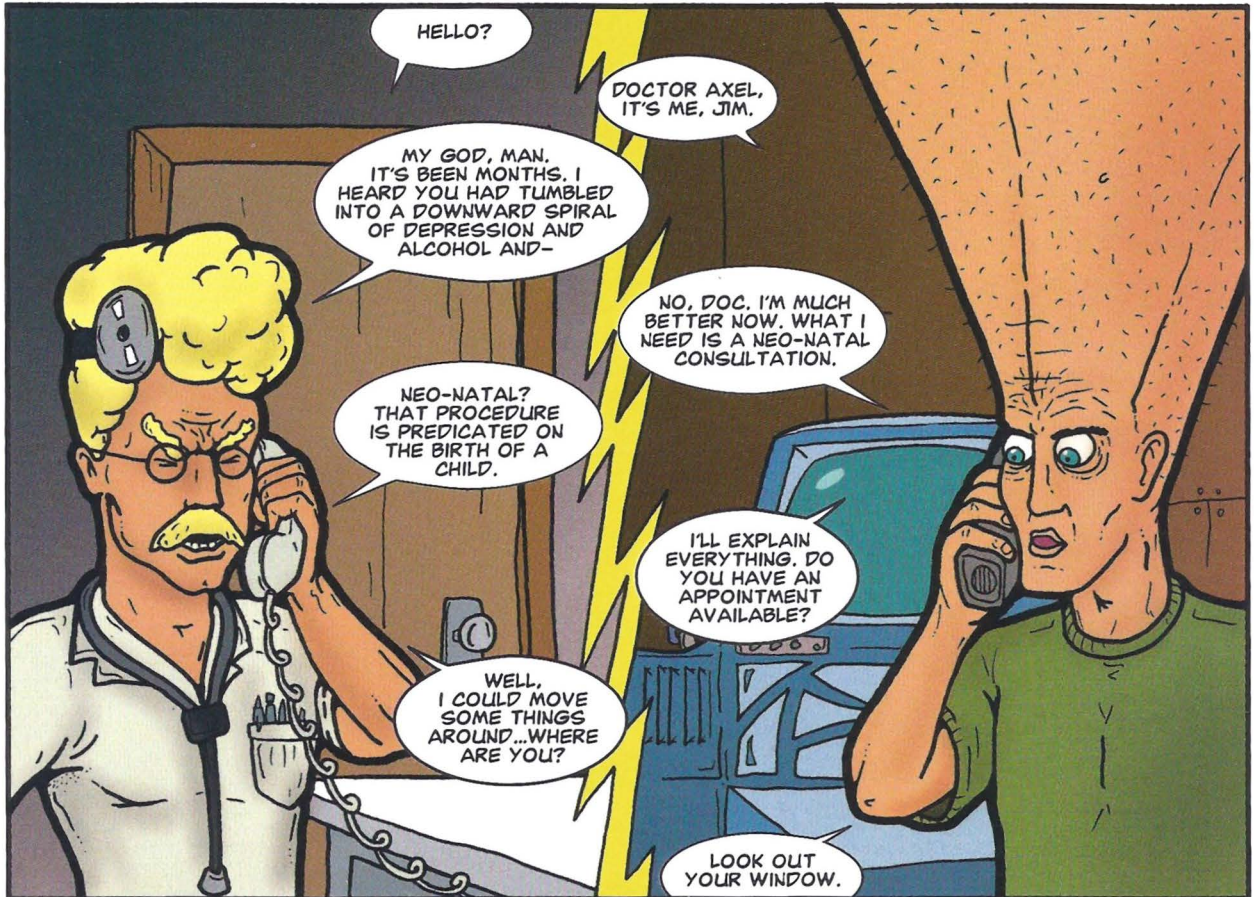

HELLO?

DOCTOR AXEL, IT'S ME, JIM.

MY GOD, MAN. IT'S BEEN MONTHS. I HEARD YOU HAD TUMBLED INTO A DOWNWARD SPIRAL OF DEPRESSION AND ALCOHOL AND--

NO, DOC. I'M MUCH BETTER NOW. WHAT I NEED IS A NEO-NATAL CONSULTATION.

NEO-NATAL? THAT PROCEDURE IS PREDICATED ON THE BIRTH OF A CHILD.

I'LL EXPLAIN EVERYTHING. DO YOU HAVE AN APPOINTMENT AVAILABLE?

WELL, I COULD MOVE SOME THINGS AROUND...WHERE ARE YOU?

LOOK OUT YOUR WINDOW.

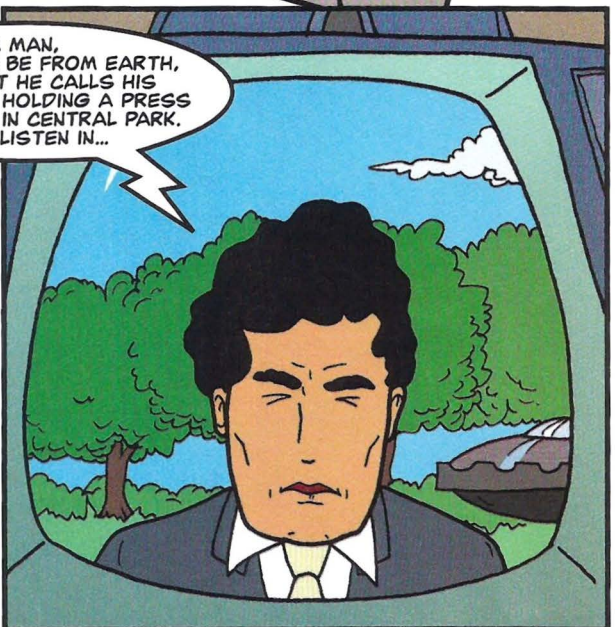
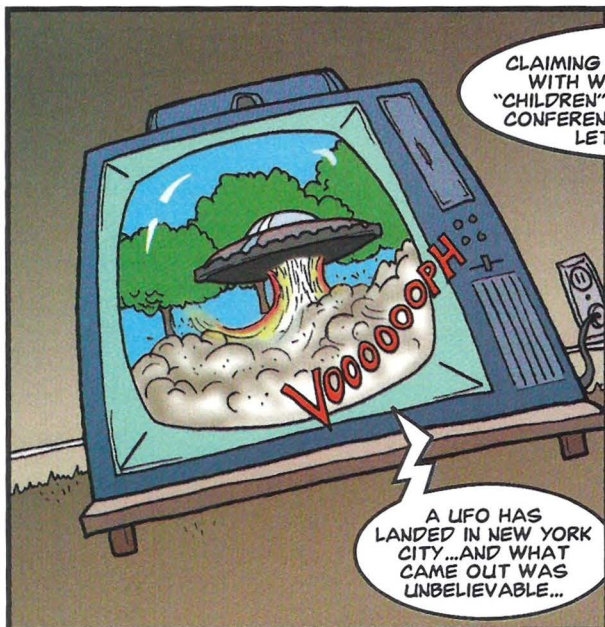
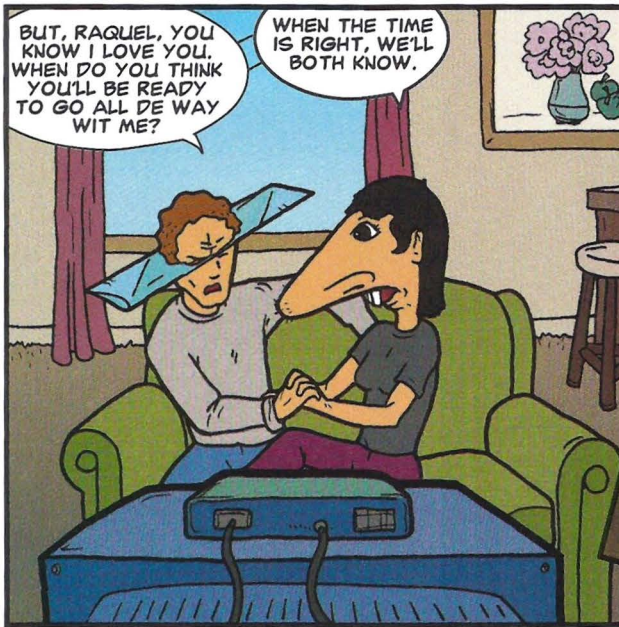

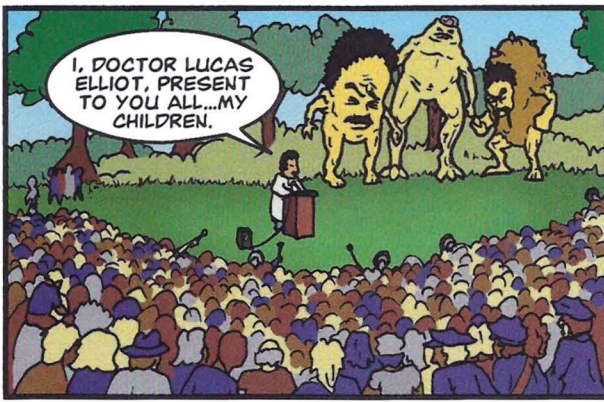

I, DOCTOR LUCAS ELLIOT, PRESENT TO YOU ALL...MY CHILDREN.

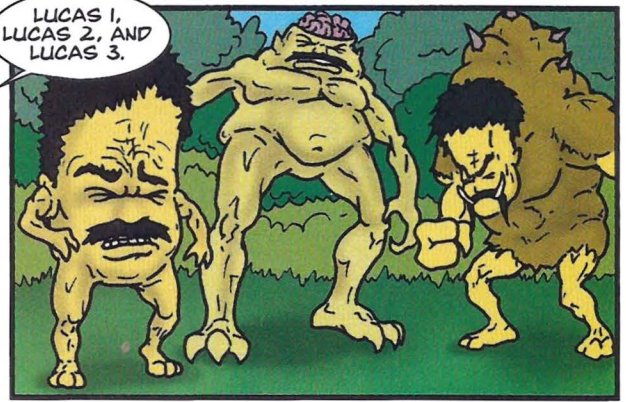

LUCAS 1, LUCAS 2, AND LUCAS 3.

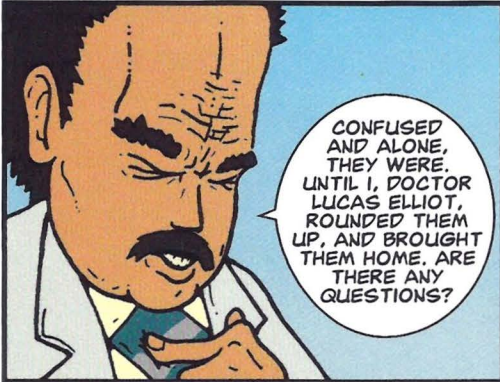

CONFUSED AND ALONE, THEY WERE. UNTIL I, DOCTOR LUCAS ELLIOT, ROUNDED THEM UP, AND BROUGHT THEM HOME. ARE THERE ANY QUESTIONS?



YOUR MONSTERS-AH, I MEAN CHILDREN-SEEM VERY WELL BEHAVED. ARE YOU USING SOME KIND OF SEDATIVE TO KEEP THEM UNDER CONTROL.

I USE NO SEDATIVE TO MAINTAIN CONTROL...



...DISCIPLINE, COUPLED WITH THE LOVE ONLY A FATHER CAN PROVIDE...

MMM...



...IS ALL I NEED TO KEEP MY BABIES WELL BEHAVED.



LET THIS BE AN EXAMPLE TO ALL FATHERS...

AAAAAIEEE



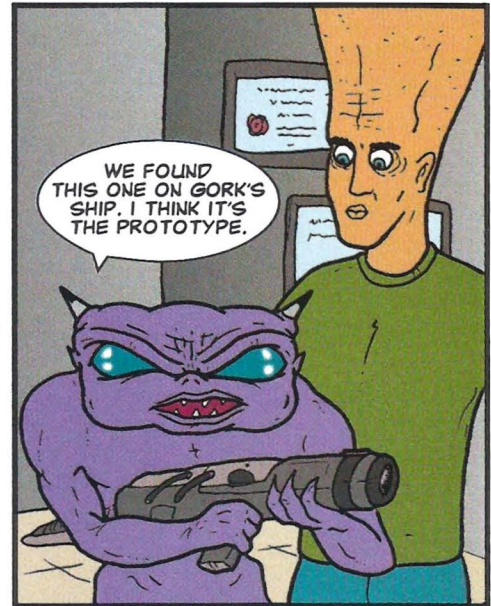
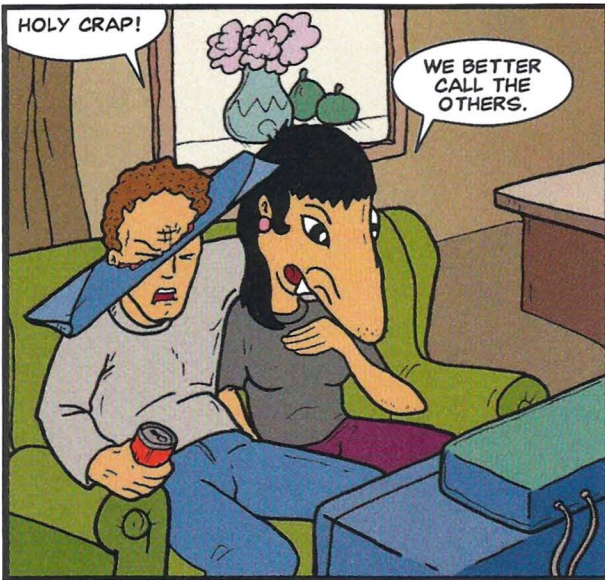

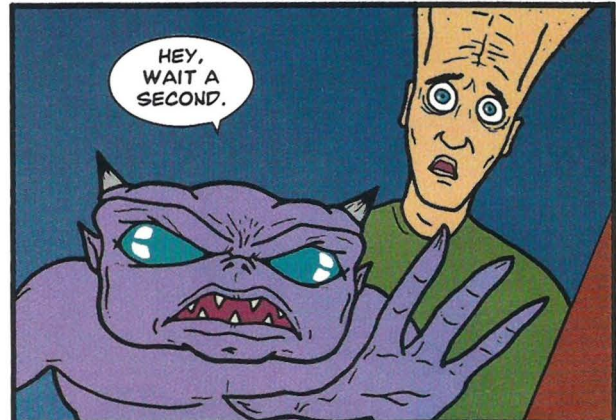
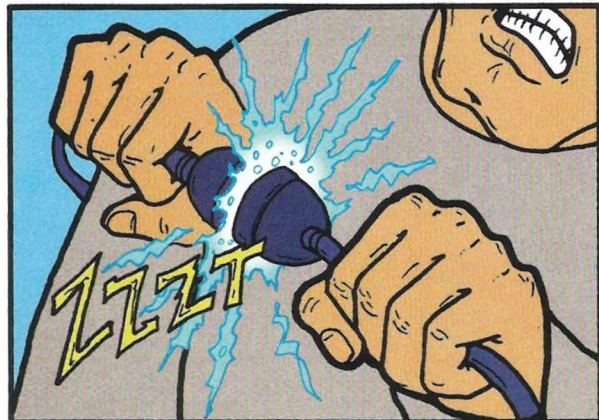
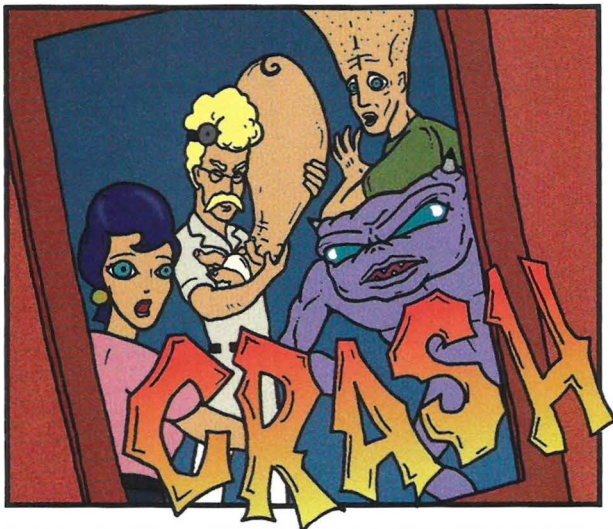





I DON'T LIKE THIS!

NAH, IT'S GONNA BE OKAY.



AXEL'S GONNA HIT US WITH THE GROWTH BEAM, AND WE'LL GET REAL BIG.

THEN WE'LL BEAT THE CRAP OUT OF THOSE MONSTERS!



ARE YOU BOYS READY?



FIRE AWAY, DOC!

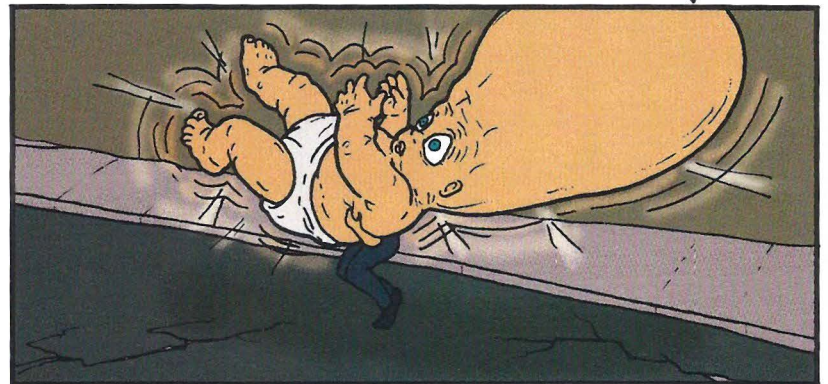

BY THE...GODS OF OLYMPUS.

THIS CAN'T BE HAPPENING.

NICE SHOOTING.

THAT'S A BIG BABY

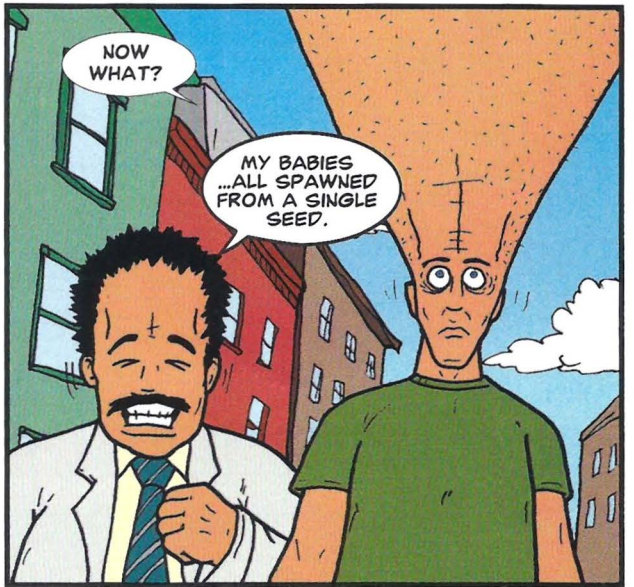
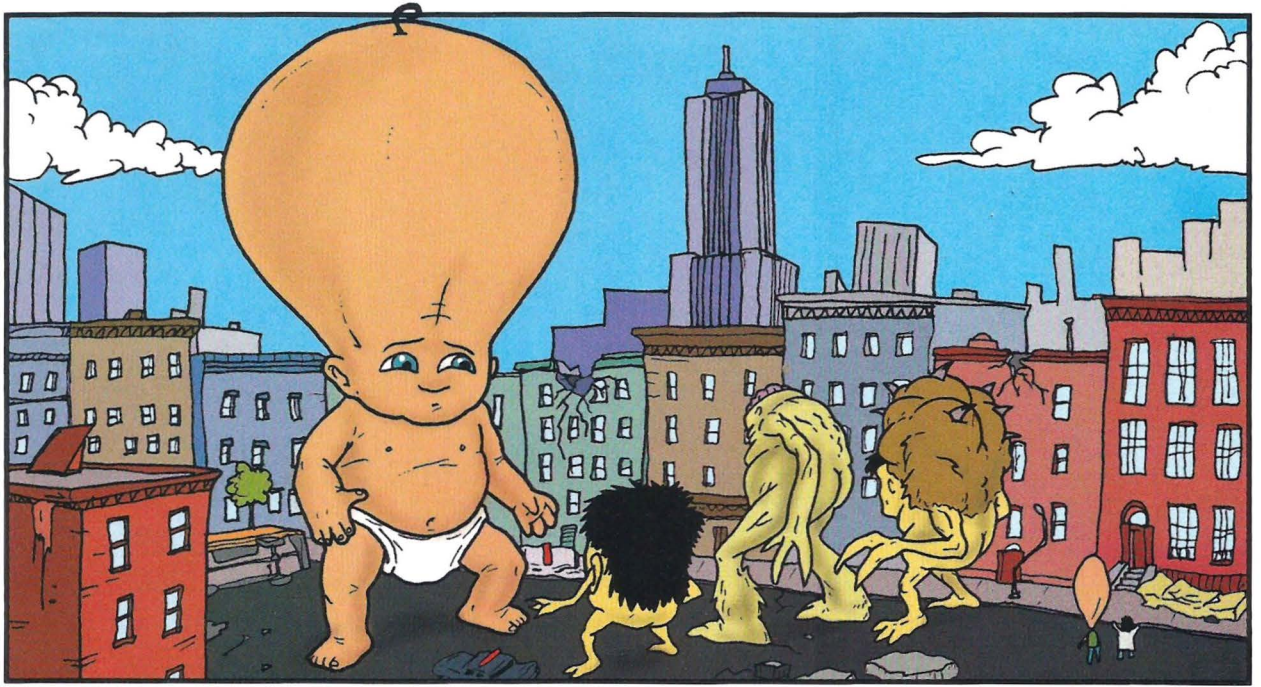

AS THEIR DEFENSIVE INSTINCTS KICK IN...

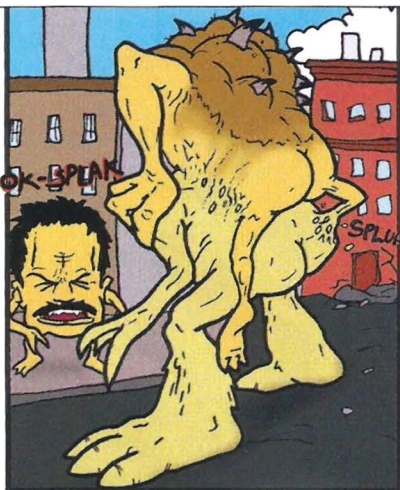

...THEY CONVERGE TO FORM...

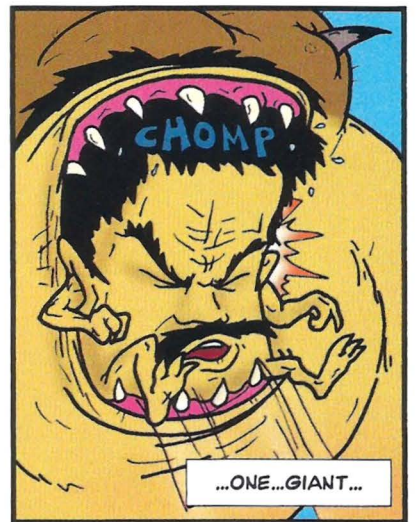
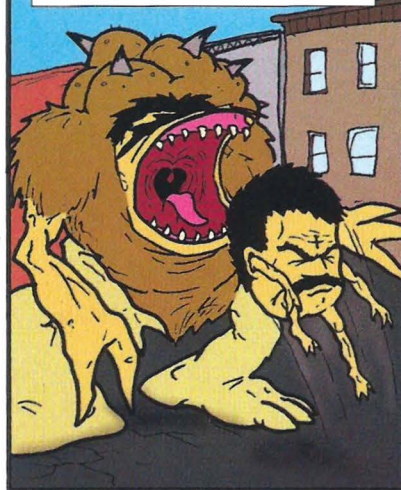



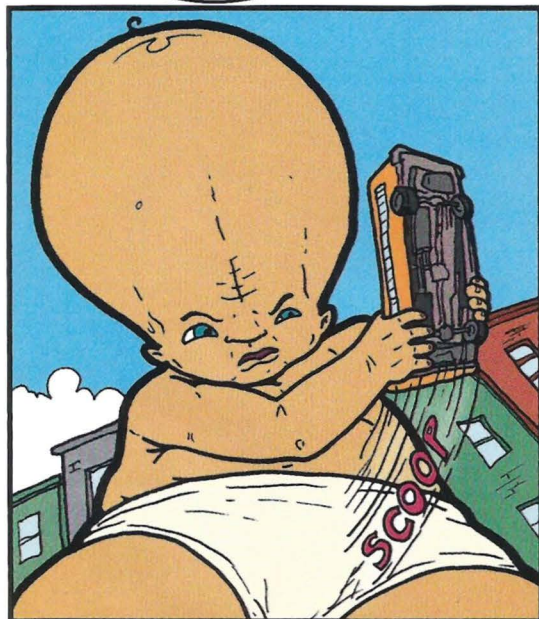
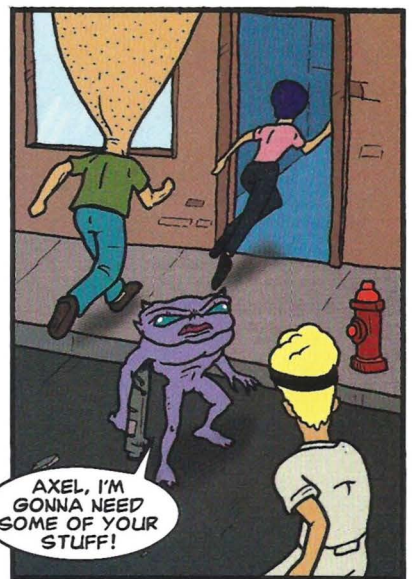

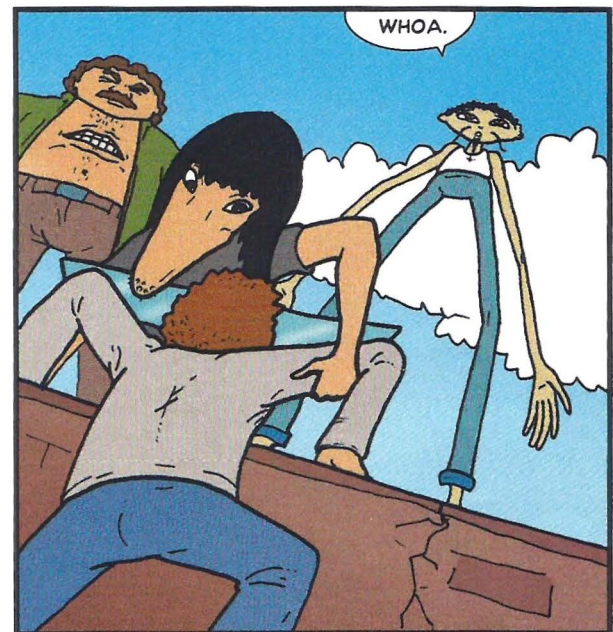
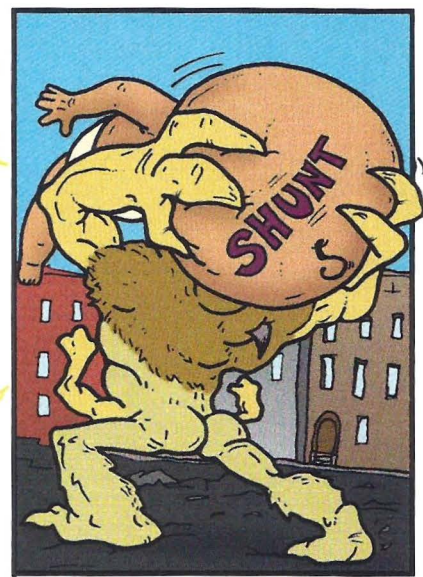
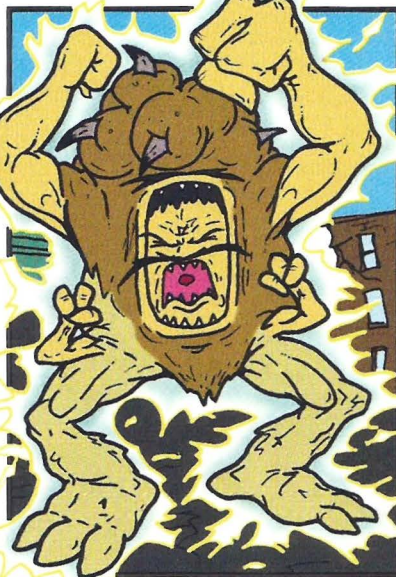

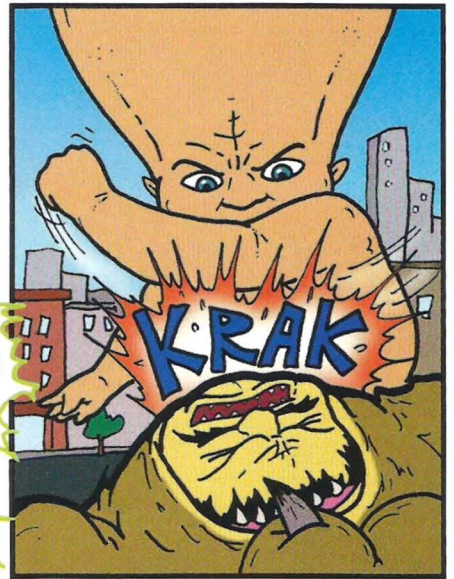
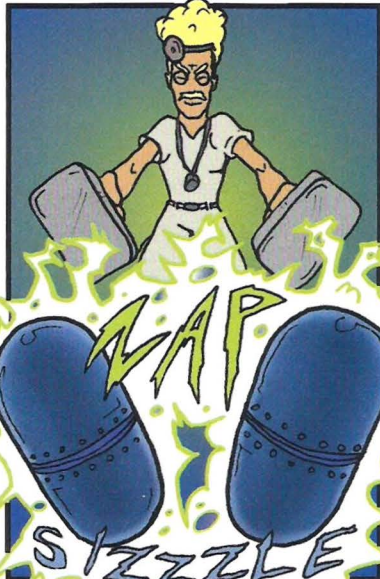

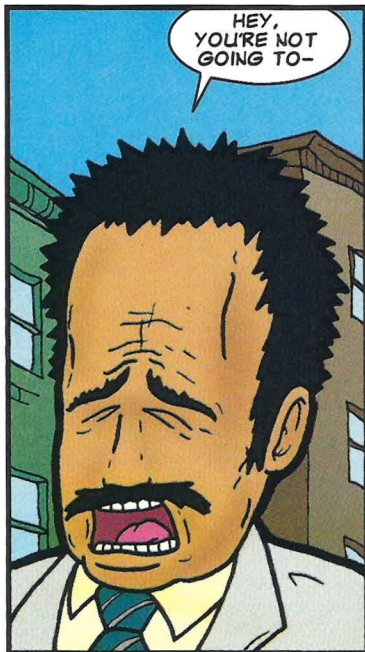
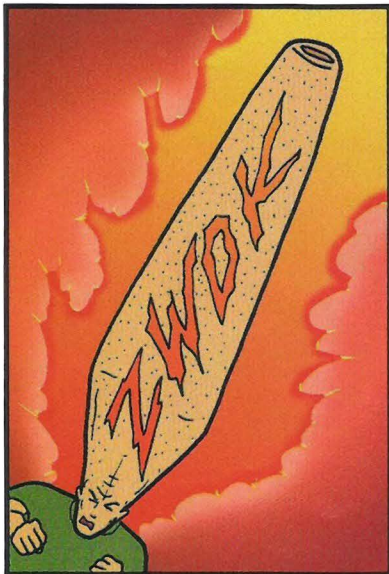
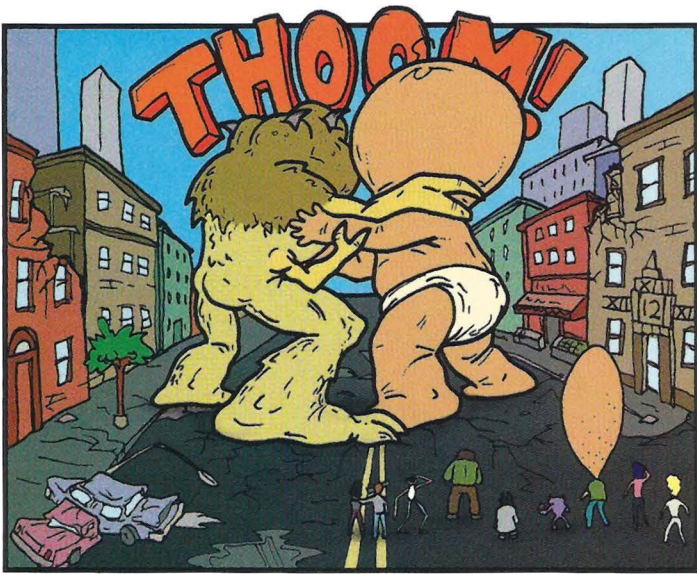

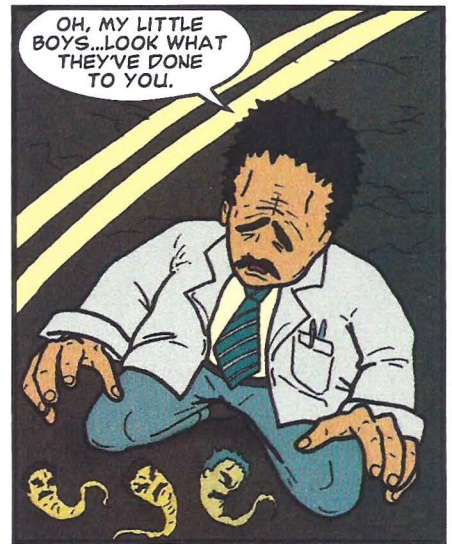
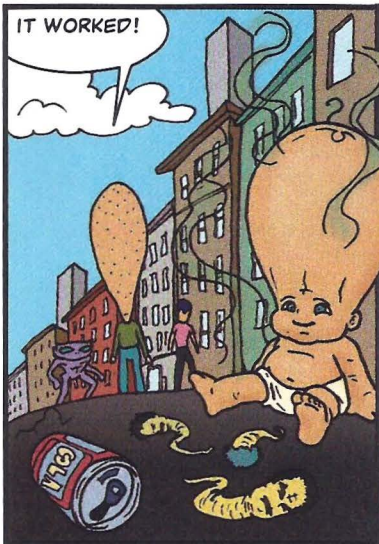
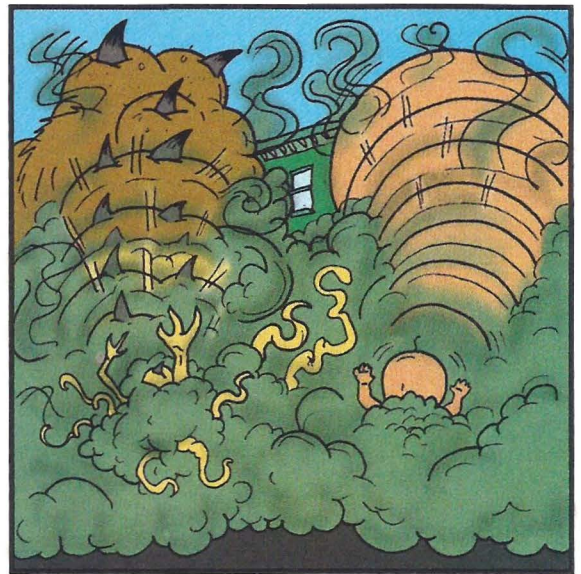
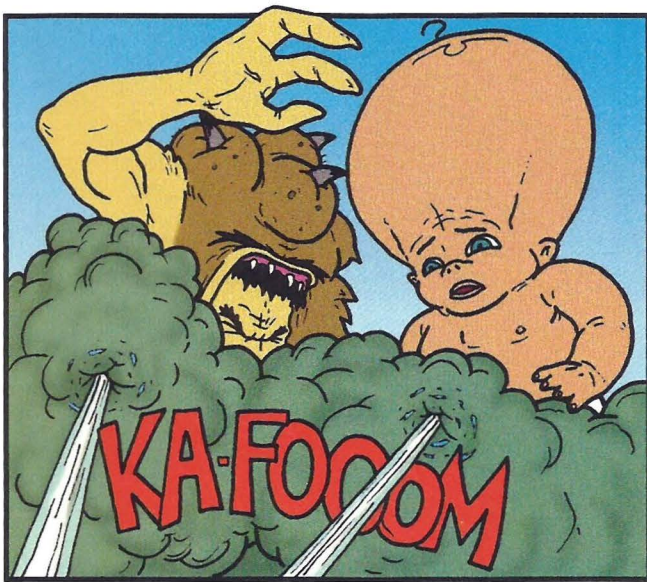

Created by Eric Fogel

Writers: Eric Fogel, Gordon Barnett

Production Supervision: Dominic Mahl

Art and Computer Supervisor: Patrick Worlock

Artists: Chris Prynosi, Jody Schaeffer, Brad McDonald, Matt Sheridan

Digital Ink and Paint Coordination: David McGrath

Digital Ink and Paint: Soo Kim, James Edwards

Digital Effects: Adam Osterfeld, Chris Prynosi, Patrick Worlock, Eric Fogel

Color Design: Monica Smith, Sophie Kittredge

Production Assistant: Dave Huges

Art Direction: Roger Gorman, Reiner Design Consultants, Inc.

Design Coordination: Hannah Leider, Reiner Design Consultants, Inc.

Special Thanks at MTV: John Andrews, Eric Caulderon, Ed Paparo, Renee Presser, Maggie Shearman, Robin Silverman, Sabrina Silverberg, Donald Silvey, Abby Terkuhle, Van Toffler

A Very Special Thanks: Rhonda Cox

Special Thanks at Pocket Books: Lynda Castillo, Gina Centrello, Dave Stern, Kara Welsh, and Irene Yüss

Special Thanks at Stevenson Photo Color: Al Trivison

This book is a work of fiction. Names, characters, places and incidents are either products of the authors' imaginations or are used fictitiously.

An Original Publication of MTV Books/Pocket Books



POCKET BOOKS, a division of Simon & Schuster Inc.
1230 Avenue of the Americas, New York, NY 10020

Copyright © 1996 by MTV Networks, a division of Viacom International Inc.

All rights reserved, including the right to reproduce this book or portions thereof in any form whatsoever.
For information address Pocket Books, 1230 Avenue of the Americas, New York, NY 10020.

ISBN: 0-671-00104-3

First MTV Books/Pocket Books trade paperback printing April 1996

10 9 8 7 6 5 4 3 2 1

POCKET and colophon are registered trademarks of Simon & Schuster Inc.

MTV: MUSIC TELEVISION, MTV'S The Head and all related titles, logos, and characters are trademarks of MTV Networks, a division of Viacom International Inc.

Printed in the U.S.A.

The sale of this book without its cover is unauthorized. If you purchased this book without a cover, you should be aware that it was reported to the publisher as "unsold and destroyed." Neither the author nor the publisher has received payment for the sale of this "stripped book."





**MEET JIM AND ROY.
PLEASE DON'T STARE.**

ALTHOUGH YOU WOULDN'T BE THE FIRST, JIM AND ROY ARE THE UNLIKELY DUO WHO HAVE TRANSFORMED THE HEAD INTO MTV'S LATEST ANIMATED SERIES SENSATION. JIM'S THE ONE WITH THE BIG HEAD. ROY IS THE PURPLE ALIEN WHO LIVES IN IT. WHEN THEY GET ALONG, THEY'RE CAPABLE OF JUST ABOUT ANYTHING, AS YOU'LL DISCOVER IN THIS COMPLETELY ORIGINAL ADVENTURE BASED ON THE SERIES' LOST EPISODE...

**THE HEAD:
A LEGEND IS BORN**

SUFFERING THE EFFECTS OF A BRUISED EGO ABOUT HIS OVER-SIZED HEAD, JIM'S BEEN SPENDING A LOT OF TIME VEGGING IN HIS NEW YORK APARTMENT. ALL WHILE HIS GOOD FRIEND ROY IS MILES AWAY PUTTING ALIEN MOVES ON A FRENCH BABE. JIM'S ADVENTURES SEEM TO BE OVER -- UNTIL ROY'S ALIEN BROTHER MARK BEAMS A DISTRESS SIGNAL TO EARTH, AND JIM AND ROY MUST TEAM UP AGAIN.

51800 >
9 780671 001049
ISBN 0-671-00104-3